

2016

上海德尤电气有限公司



连接件（格兰头）

2016/8/28

目 录



| | |
|------------------|-------|
| 公司简介..... | 2~3 |
| 产品目录..... | 4~6 |
| 产品标准..... | 7~12 |
| 产品应用..... | 13 |
| 尼龙电缆防水接头..... | 14~21 |
| 金属电缆防水接头..... | 22~28 |
| 不锈钢电缆防水接头..... | 29~34 |
| 闷盖系列..... | 35~37 |
| 电缆接头附件..... | 38~40 |
| 尼龙软管接头..... | 41~50 |
| 尼龙软管支架附件..... | 51~54 |
| 金属软管接头及端式接头..... | 55~64 |
| 电气密封箱..... | 65 |

上海德尤电气有限公司致力于电缆保护和紧固产品的研发,创新和生产制造,提供完整的机械
设备,电气设备,工程安装的全方位,系统地电缆保护和紧固方案.

专业质量服务技术

高质量的产品:公司始终秉承"专业生产商,提供高品质"的理念,工厂通过了 ISO9001:1008 质量体系的
审核和认证,按国际标准生产塑料软管,金属软管,电缆接头三大类千种产品,产品通过了 CE、UL、VDE、DNV
BSI,ROAS,SGS 的认证.

领先的技术:公司拒不断创新 ,开发了多项新品,拥有专业的研发团队和全球领先的实验室,涵盖了防护 ,
烟雾 ,盐雾,燃烧线验 ,拉力,压力,精确测绘等项目的实验设备,保证品质,持续开发.







高品质的服务:我们设立了全国服务热线,提供及时的售前和售后服务.



区域化的经营:我们销售网络覆盖全国,专业销售人员提供专业选型和产品技术支持.



| | | |
|---|---|---|
|  |  |  |
| 尼龙防水接头 | 金属防水接头 | 不锈钢防水接头 |
|  |  |  |
| 金属屏蔽接头 | 尼龙螺母 | 金属螺母 |
|  |  |  |
| 尼龙圆闷盖 | 金属六角闷盖 | 金属闷圆盖 |
|  |  |  |
| 金属缩径环 | 金属增径环 | 金属变径环 |
|  |  |  |
| 铸铝机箱 | 不锈钢机箱 | 塑料密封箱 |

| | | |
|---|---|---|
|  |  |  |
| 尼龙软管 V2 | 尼龙软管 V0 | PE 软管 |
|  |  |  |
| 编织套管 | 快速软管接头 | 90 度软管接头 |
|  |  |  |
| Y 型三通接头 | 内螺纹软管接头 | 带盖软管支架 |
|  |  |  |
| 不带盖软管支架 | T 型三通接头 | 软管闷头 |

| | | |
|---|--|---|
|  |  |  |
| <p style="text-align: center;">不锈钢软管</p> | <p style="text-align: center;">不锈钢包塑软管</p> | <p style="text-align: center;">金属包塑软管</p> |
|  |  |  |
| <p style="text-align: center;">编织套管</p> | <p style="text-align: center;">不锈钢编织金属软管</p> | <p style="text-align: center;">90 度软管接头</p> |

| | | | |
|--|--|---|---|
| |  A close-up photograph of an aluminum end fitting. It features a hexagonal base with a blue O-ring seal and a threaded section on the side. |  A close-up photograph of a stainless steel end fitting. It has a hexagonal base and a threaded section, with a blue O-ring seal visible inside the opening. |  A close-up photograph of a metal end fitting, likely stainless steel. It has a hexagonal base and a threaded section, with a blue O-ring seal visible inside the opening. |
| | <p>铝合金端式接头</p> | <p>不锈钢端式接头</p> | <p>金属端式接头</p> |

产品标准

| 产品测试/技术要求 | 国际标准 | 中国国家标准 |
|----------------------|---|--|
| 电缆防水接头整体要求 | EN50262 / UL514B 用于电器保护的电缆防水接头整体要求 | |
| 电缆防水接头 燃烧性能 | EN60695-2 / IEC60695 VDE 0471 T.2-4/1, UL94 塑料产品的防火性能测试 | |
| 电缆防水接头 螺纹标准 | DIN 40430 PG 螺纹标准要求 DIN / EN 60423 M 公制螺纹标准要求 ANSI/ASME B 1.20.1 NPT 英制螺纹标准 ISO 228-1 / JIS B 0204 G 管螺纹标准 | GB/T192-2003 国标公制螺纹 GB/T196-2003 国标公制螺纹 GB/T706.1-2000 管螺纹 GB/T706.1-2000 NPT 锥螺纹 |
| 电缆防水接头 整体防护性能 | EN62444 / DIN 40050 / IEC60529 电气产品防护等级测试标准 | GB/T 4208.-93 Eqv. IEC60034-5:2000 IP 防护等级 |
| 电缆防水接头 扭矩要求 | EN62444 电缆防水接头的抗拉、抗扭要求 | |
| 电缆防水接头对电气产品 的保护要求 | EN 60204-1 / VDE 0113-1 有关机器安全保护要求的综述 | |
| 电磁兼容电缆防水接头 | IEC61000-4-1-2000 | GB/T.17626.1-2006 |

电缆防水接头扭矩标准VDE0619 cable gland twisting standard for torque moment

| 螺纹规格 thread dimension | 夹紧接头cable gland | | 螺母lock nut | |
|-----------------------------|-----------------|-------------|---------------|-------------|
| | 塑料 plastic | 金属 metal | 塑料 plastic | 金属 metal |
| Pg7/M12 | 1.3 | 3.5 | 1.2 | 4.17 |
| Pg9/M16 | 2.5 | 6.25 | 1.5 | 4.17 |
| Pg11/M18 | 3.75 | 6.25 | 2 | 4.17 |
| Pg13.5/M20 | 3.75 | 6.25 | 2 | 4.17 |
| Pg16/M22/M24 | 5 | 7.5 | 3.33 | 5 |
| M25 | 7.5 | 10 | 3.33 | 6.67 |
| Pg21/M27/M30 | 7.5 | 10 | 5 | 6.67 |
| Pg29/M32/M33/M36 | 7.5 | 10 | 5 | 6.67 |
| Pg36/M40/M42/M48 | 7.5 | 10 | 5 | 6.67 |
| Pg42/M50/M56 | 7.5 | 10 | 5 | 6.67 |
| Pg48/M63/M64 | 10 | 12.5 | 5 | 6.67 |

螺纹标准技术说明

1. EN60423 公制螺纹 M，用于电气产品接口，正在被欧洲广泛使用，代替 PG 螺纹
2. DIN40430 德国螺纹 PG，现在已经被逐渐取消
3. GB/T192-2003, GB/T 196-2003, ISO724-1978，国标螺纹，中国广泛使用
4. ANSI B 1.20.1, NPT 英制螺纹，北美使用
5. G 管螺纹，世界广泛使用，主要是管道或工程
6. UNEF 英制螺纹，广泛使用于连接器行业
7. PF 英制螺纹，日本广泛使用

公制螺纹 M — 螺纹标准

螺纹标准: EN60423

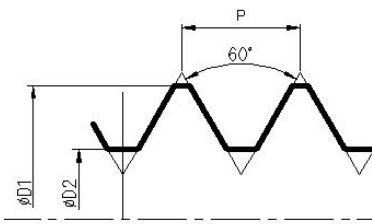

| 螺纹规格 | 螺距 | 外径 d1 | 底径 d2 | 螺牙角度 | 开孔 |
|------|-----|-------|-------|------|-----------|
| 10 | 1.0 | 10 | 8.92 | 60 | 10 +0.4mm |
| 12 | 1.5 | 12 | 10.38 | 60 | 12 +0.4mm |
| 16 | 1.5 | 16 | 14.38 | 60 | 16 +0.4mm |
| 20 | 1.5 | 20 | 18.38 | 60 | 20 +0.4mm |
| 25 | 1.5 | 25 | 23.38 | 60 | 25 +0.4mm |
| 32 | 1.5 | 32 | 30.38 | 60 | 32 +0.4mm |
| 40 | 1.5 | 40 | 38.38 | 60 | 40 +0.5mm |
| 50 | 1.5 | 50 | 48.38 | 60 | 50 +0.5mm |
| 63 | 1.5 | 63 | 61.38 | 60 | 63 +0.5mm |

公制螺纹 GM — 螺纹标

螺纹标准: GB/T192-2003, GB/T 196-2003, ISO724-1978)

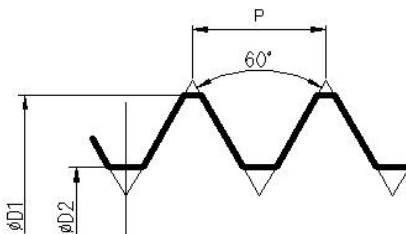

| 螺纹规格 | 螺距 | 外径 d1 | 底径 d2 | 螺牙角度 | 开孔 |
|------|-----|-------|-------|------|-----------|
| 12 | 1.5 | 12 | 10.38 | 60 | 12 +0.4mm |
| 16 | 1.5 | 16 | 14.38 | 60 | 16 +0.4mm |
| 18 | 1.5 | 18 | 16.38 | 60 | 18 +0.4mm |
| 20 | 1.5 | 20 | 18.38 | 60 | 20 +0.4mm |
| 22 | 1.5 | 22 | 20.38 | 60 | 22 +0.4mm |
| 24 | 1.5 | 24 | 22.38 | 60 | 24 +0.4mm |
| 27 | 2.0 | 27 | 24.84 | 60 | 27 +0.4mm |
| 30 | 2.0 | 30 | 27.84 | 60 | 30 +0.4mm |
| 33 | 2.0 | 33 | 30.84 | 60 | 33 +0.4mm |
| 36 | 2.0 | 36 | 33.84 | 60 | 36 +0.4mm |
| 48 | 2.0 | 48 | 45.84 | 60 | 48 +0.5mm |
| 56 | 2.0 | 56 | 53.84 | 60 | 56 +0.5mm |
| 60 | 2.0 | 60 | 57.84 | 60 | 60 +0.5mm |
| 64 | 2.0 | 64 | 61.84 | 60 | 64 +0.5mm |
| 72 | 2.0 | 72 | 69.84 | 60 | 72 +0.5mm |

德国 PG 制 — 螺纹标准与技术数据

螺纹标准: DIN40430



| 螺纹规格 | 螺距 | 外径 d1 | 底径 d2 | 螺牙角度 | 开孔尺寸 |
|------|-------|-------|-------|------|-------------|
| 7 | 1.27 | 12.5 | 11.28 | 80 | 12.5 +0.4mm |
| 9 | 1.41 | 15.2 | 13.86 | 80 | 15.2 +0.4mm |
| 11 | 1.41 | 18.6 | 17.26 | 80 | 18.6 +0.4mm |
| 13.5 | 1.41 | 20.4 | 19.06 | 80 | 20.4 +0.4mm |
| 16 | 1.41 | 22.5 | 21.16 | 80 | 22.5 +0.4mm |
| 21 | 1.588 | 28.3 | 26.78 | 80 | 28.3 +0.4mm |
| 29 | 1.588 | 37.0 | 35.48 | 80 | 37.0 +0.4mm |
| 36 | 1.588 | 47.0 | 45.48 | 80 | 47.0 +0.5mm |
| 42 | 1.588 | 54.0 | 52.48 | 80 | 54.0 +0.5mm |
| 48 | 1.588 | 59.3 | 57.78 | 80 | 59.3 +0.5mm |

NPT 英制 — 螺纹标准与技术数据

螺纹标准: ANSI B 1.20.1



| 螺纹规格 | 螺距 | 基径 d1 | 底径 d2 | 牙数 | 螺牙角度 | 基本长度 |
|----------|-------|-------|-------|------|------|------|
| NPT1/4 | 1.411 | 13.62 | 11.36 | 18 | 60 | 10 |
| NPT3/8 | 1.411 | 17.06 | 14.8 | 18 | 60 | 10.3 |
| NPT1/2 | 1.814 | 21.22 | 18.32 | 14 | 60 | 13.6 |
| NPT3/4 | 1.814 | 26.57 | 23.67 | 14 | 60 | 14.1 |
| NPT1 | 2.208 | 33.23 | 29.69 | 11.5 | 60 | 16.8 |
| NPT1 1/2 | 2.208 | 48.05 | 44.52 | 11.5 | 60 | 17.3 |
| NPT2 | 2.208 | 60.09 | 56.56 | 11.5 | 60 | 17.7 |
| NPT2 1/2 | 3.175 | 72.70 | 67.62 | 8 | 60 | 23.7 |

UNEF 统一英制 — 螺纹标准与技术数据

螺纹标准: ANSI B 1.20.1

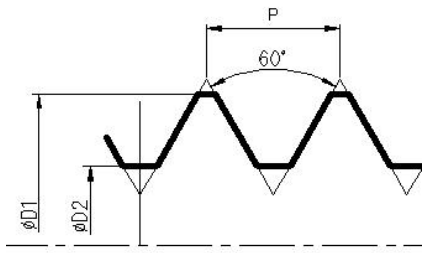

| 螺纹规格 | 螺距 | 外径 d1 | 底径 d2 | 牙数 | 螺牙角度 | 开孔尺寸 |
|--------------|-------|-------|-------|----|------|--------------|
| UNEF 1/2" | 0.907 | 12.70 | 11.72 | 28 | 60 | 12.70 +0.4mm |
| UNEF 5/8" | 1.058 | 15.88 | 14.73 | 24 | 60 | 15.88 +0.4mm |
| UNEF 3/4" | 1.270 | 19.05 | 17.68 | 20 | 60 | 19.05 +0.4mm |
| UNEF 7/8" | 1.270 | 22.23 | 20.86 | 20 | 60 | 22.23 +0.4mm |
| UNEF 15/16" | 1.270 | 23.81 | 22.44 | 20 | 60 | 23.81 +0.4mm |
| UNEF 1" | 1.270 | 25.40 | 24.03 | 20 | 60 | 25.40 +0.4mm |
| UNEF 1-3/16" | 1.411 | 30.16 | 28.63 | 18 | 60 | 30.16 +0.4mm |
| UNEF 1-3/8" | 1.411 | 34.93 | 33.40 | 18 | 60 | 34.93 +0.4mm |

G / PF — 螺纹标准与技术数据

螺纹标准: JIS B0204 / ISO228-1 管螺纹

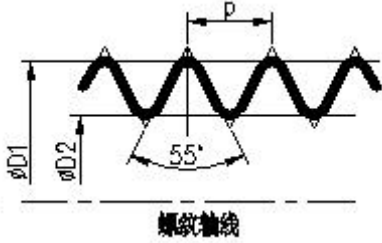

| 螺纹规格 | 螺距 | 外径 d1 | 底径 d2 | 牙数 | 螺牙 角度 | 开孔 尺寸 |
|--------|-------|----------|--------|----|----------|--------------|
| G1/4 | 1.337 | 13.16 | 11.45 | 19 | 55 | 13.16 +0.4mm |
| G3/8 | 1.337 | 16.66 | 14.95 | 19 | 55 | 16.66+0.4mm |
| G1/2 | 1.814 | 20.99 | 18.63 | 14 | 55 | 20.99+0.4mm |
| G3/4 | 1.814 | 26.44 | 24.12 | 14 | 55 | 26.44+0.4mm |
| G1 | 2.309 | 33.25 | 30.25 | 11 | 55 | 33.25+0.4mm |
| G1 1/4 | 2.309 | 41.91 | 38.95 | 11 | 55 | 41.91+0.5mm |
| G1 1/2 | 2.309 | 47.80 | 44.85 | 11 | 55 | 47.80+0.5mm |
| G2 | 2.309 | 59.61 | 56.66 | 11 | 55 | 59.61+0.5mm |
| G2 1/2 | 2.309 | 75.18 | 72.23 | 11 | 55 | 75.18+0.5mm |
| G3 | 2.309 | 87.88 | 84.93 | 11 | 55 | 87.88+0.5mm |
| G3 1/2 | 2.309 | 100.33 | 97.37 | 11 | 55 | 100.33+0.5mm |
| G4" | 2.309 | 113.03 | 110.07 | 11 | 55 | 113.03+0.5mm |

** 等同日本的 PF 螺纹

NPS 英制 — 螺纹标准与技术数据

螺纹标准: ANSI B 1.20.1

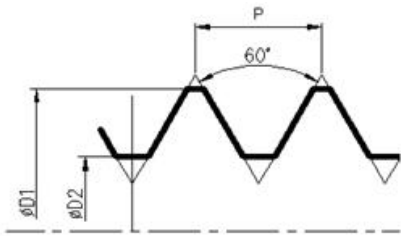

| 螺纹规格 | 螺距 | 基径 d1 | 底径 d2 | 牙数 | 螺牙 角度 | 开孔 尺寸 |
|----------|-------|-------|-------|--------|----------|-------------|
| NPS1/4 | 1.411 | 13.62 | 11.36 | 18 | 60 | 13.62+0.4mm |
| NPS3/8 | 1.411 | 17.06 | 14.8 | 18 | 60 | 17.06+0.4mm |
| NPS1/2 | 1.814 | 21.22 | 18.32 | 14 | 60 | 21.22+0.4mm |
| NPS3/4 | 1.814 | 26.57 | 23.67 | 14 | 60 | 26.57+0.4mm |
| NPS1 | 2.208 | 33.23 | 29.69 | 11 1/2 | 60 | 33.23+0.4mm |
| NPS1 1/2 | 2.208 | 48.05 | 44.52 | 11 1/2 | 60 | 48.05+0.5mm |
| NPS2 | 2.208 | 60.09 | 56.56 | 11 1/2 | 60 | 60.09+0.5mm |
| NPS2 1/2 | 3.175 | 72.70 | 67.62 | 8 | 60 | 72.70+0.5mm |

IP 防护等级的意义-按照 EN60529 (IP), EN50102(K)

| IP6 | 防尘保护等级 (第二个数字) | | IP | 防水保护等级 (第二个数字) | |
|-----|---|------------|----|--|---|
| 0 | | 表示没有防护 | 0 | | 表示没有防护 |
| 1 | | | 1 |  | 可防止竖直落水的危害 |
| 2 | | | 2 |  | 可防止竖直方向成 15° 角以下直接喷水的危害 |
| 3 | | | 3 |  | 可防止竖直方向成 60° 角以下直接喷水的危害 |
| 4 | | | 4 |  | 可防止来自各个方向上直接喷水的危害 室内灯具, 按钮盒等 |
| 5 |  | 可防止粉尘的危害。 | 5 |  | 可防止来自各个方向上低压水喷射的危害 灯具, 马达 |
| 6 |  | 完全防止粉尘的危害。 | 6 |  | 可防止来自各个方向上高压水喷射的危害 接线箱, 按钮盒 |
| | | | 7 |  | 可防止 15cm~1m 之间浸没的危害 电机, 仪表, 接线盒 |
| | | | 8 |  | 可防止在压力下长期浸没的危害 |

防腐级别：参照 JB/T9536-1999（户内、户外防腐低压电器环境技术要求）

UL94 标准 — 技术说明

UL94 HB

试验材料在水平测试中应该燃烧缓慢，厚度不超过 3mm 时的燃烧速度不能超过 3 英寸/分钟（76mm/分钟）；厚度大于 3mm 时的速度不能超过 1.5 英寸/分钟（3.8mm/分钟）；超过此燃烧速度的任何材料均不能获得 UL 认可。

UL94 V2

在垂直燃烧试验中，平均自熄时间不能超过 25 秒（单次时间不能超过 30 秒），燃烧产生的滴落物可能引燃下方的棉物。点燃后，任何可能的燃烧时间均不能超过 60 秒。

UL94 V1

在垂直燃烧试验中，平均自熄时间不能超过 25 秒（单次时间不能超过 30 秒），燃烧产生的滴落物不可以引燃下方的棉物。点燃后，任何可能的燃烧时间均不能超过 30 秒。

UL94 V0

在垂直燃烧试验中，平均自熄时间不能超过 5 秒（单次时间不能超过 10 秒），燃烧产生的滴落物不能引燃下方的棉物。点燃后，任何可能的燃烧时间均不能超过 30 秒。

德国 S4 标准（根据 DIN5510） — 技术说明

耐火等级 S4 — 测试过程按 DIN54837 标准

要求：破坏长度 ≤ 20cm，无燃烧情况

如果试验区的样品点燃后的燃烧平均时间不超过 10 秒，也可以认为该产品达到了 S4 等级；如果任何非试验区里的样品产生燃烧则不能认为该产品达到 S4 等级。

如果试验区样品的燃烧时间超过 120 秒，则不能认为该产品达到了 S4 等级（根据 DIN54837 标准，样品必须在点燃后 120 秒内自熄）。

常见国家标准和认证



欧共体安全标准
Europe committee



UL 认证标志

VDE

德国电气协会标准

GB

中国国家标准



美国和加拿大共同认可的
UL (Underwriter Lab) 列表标志

DIN

德国国家工业标准

产品应用



NCG 尼龙电缆防水接头(连体式)

- 产品材质：PA6,(防火等级 UL94-V0);
- 橡胶件：耐候三元乙丙橡胶;
- 温度：-40℃—+100℃;
- 防护等级：IP68
- 颜色种类：黑色、灰色,选购时请确定 B (黑色),G (灰色)
- 产品特性:

双螺纹，连接更顺畅，O 型圈环槽，连接更紧密改进型护套，保护连接安全。

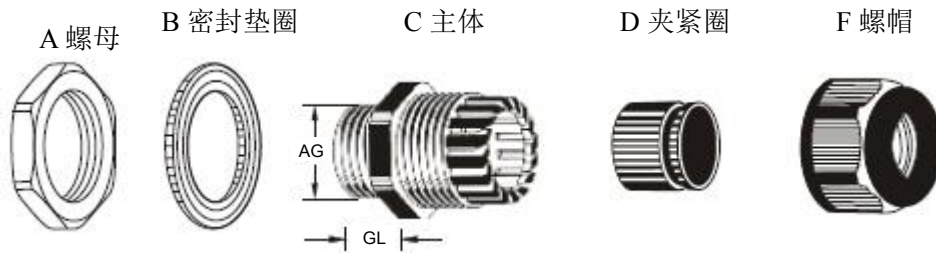
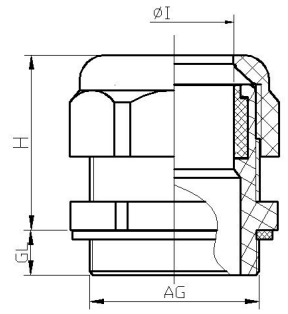

NCG 尼龙电缆防水接头(连体式)

- 产品材质：PA6,(防火等级 UL94-V0);
- 橡胶件：耐候三元乙丙橡胶;
- 温度：-40℃—+100℃;
- 防护等级：IP68
- 颜色种类：黑色、灰色,选购时请确定 B (黑色),G (灰色)
- 产品特性:

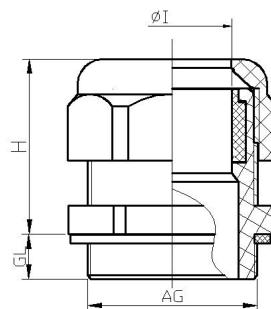

双螺纹，连接更顺畅，O型圈环槽，连接更紧密改进型护套，保护连接安全。

NCG-M ×1.5 欧标公制螺纹

| 型号 | 卡口范围 | 螺纹外径 (AG) | 螺纹长度 (GL) | 高度 (H) | 扳手尺寸 | 包装单位 | 订货编号 (黑色) | 订货编号 (灰色) |
|---------|-------|-----------|-----------|--------|-------|------|-------------|-------------|
| M12×1.5 | 3-6.5 | 12 | 8 | 21 | 15 | 100 | NCG-M12.B | NCG-M12.G |
| M16×1.5 | 4-8 | 16 | 8 | 22 | 19 | 100 | NCG-M16A.B | NCG-M16A.G |
| M16×1.5 | 5-10 | 16 | 8 | 25 | 22 | 100 | NCG-M16B.B | NCG-M16B.G |
| M18×1.5 | 5-10 | 18 | 8 | 25 | 22 | 100 | NCG-M18.A.B | NCG-M18.A.G |
| M18×1.5 | 3-7 | 18 | 8 | 25 | 22 | 100 | NCG-M18.B.B | NCG-M18.B.G |
| M20×1.5 | 6-12 | 20 | 9 | 27 | 24 | 100 | NCG-M20.A.B | NCG-M20.A.G |
| M20×1.5 | 5-9 | 20 | 9 | 27 | 24 | 100 | NCG-M20.B.B | NCG-M20.B.G |
| M20×1.5 | 8-14 | 20 | 10 | 27 | 27 | 100 | NCG-M20.C.B | NCG-M20.C.G |
| M22×1.5 | 8-14 | 22 | 10 | 28 | 27 | 50 | NCG-M22.A.B | NCG-M22.A.G |
| M22×1.5 | 6-12 | 22 | 10 | 28 | 27 | 50 | NCG-M22.B.B | NCG-M22.B.G |
| M25×1.5 | 13-18 | 25 | 11 | 31 | 33 | 50 | NCG-M25.A.B | NCG-M25.A.G |
| M25×1.5 | 9-16 | 25 | 11 | 31 | 33 | 50 | NCG-M25.B.B | NCG-M25.B.G |
| M32×1.5 | 18-25 | 32 | 11 | 39 | 42 | 25 | NCG-M32.A.B | NCG-M32.A.G |
| M32×1.5 | 13-20 | 32 | 11 | 39 | 42 | 25 | NCG-M32.B.B | NCG-M32.B.G |
| M40×1.5 | 22-32 | 40 | 13 | 48 | 53 | 20 | NCG-M40.A.B | NCG-M40.A.G |
| M40×1.5 | 20-26 | 40 | 13 | 48 | 53 | 20 | NCG-M40.B.B | NCG-M40.B.G |
| M50×1.5 | 32-38 | 50 | 15 | 49 | 60 | 16 | NCG-M50.A.B | NCG-M50.A.G |
| M50×1.5 | 25-31 | 50 | 15 | 49 | 60 | 16 | NCG-M50.B.B | NCG-M50.B.G |
| M63×1.5 | 37-44 | 63 | 15 | 49 | 65/68 | 12 | NCG-M63.A.B | NCG-M63.A.G |
| M63×1.5 | 29-35 | 63 | 15 | 49 | 65/68 | 12 | NCG-M63.B.B | NCG-M63.B.G |
| M72×1.5 | 43-53 | 72 | 16 | 54 | 86 | 12 | NCG-M72.A.B | NCG-M72.A.G |
| M72×1.5 | 51-57 | 72 | 16 | 54 | 86 | 12 | NCG-M72.B.B | NCG-M72.B.G |

NCG 尼龙电缆防水接头(连体式)

- 产品材质：PA6,(防火等级 UL94-V0);
- 橡胶件：耐候三元乙丙橡胶;
- 温度：-40℃—+100℃;
- 防护等级：IP68
- 颜色种类：黑色、灰色,选购时请确定 B (黑色),G (灰色)
- 产品特性:

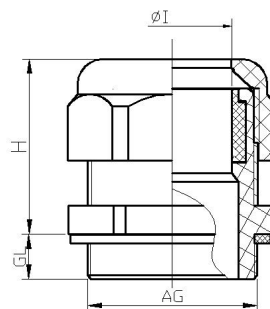

双螺纹，连接更顺畅，O型圈环槽，连接更紧密改进型护套，保护连接安全。

NCG-PG 德制螺纹

| 型号 | 卡口范围 | 螺纹外径 (AG) | 螺纹长度 (GL) | 高度 (H) | 扳手尺寸 | 包装单位 | 订货编号 (黑色) | 订货编号 (灰色) |
|--------|-------|-----------|-----------|--------|------|------|--------------|--------------|
| PG7 | 3-6.5 | 12.5 | 8 | 21 | 15 | 100 | NCG-PG7.A.B | NCG-PG7.A.G |
| PG7 | 2-5 | 12.5 | 8 | 21 | 15 | 100 | NCG-PG7.B.B | NCG-PG7.B.G |
| PG9 | 4-8 | 15.2 | 8 | 22 | 19 | 100 | NCG-PG9.A.B | NCG-PG9.A.G |
| PG9 | 2-6 | 15.2 | 8 | 22 | 19 | 100 | NCG-PG9.B.B | NCG-PG9.B.G |
| PG11 | 5-10 | 18.6 | 8 | 25 | 22 | 100 | NCG-PG11.A.B | NCG-PG11.A.G |
| PG11 | 3-7 | 18.6 | 9 | 25 | 22 | 100 | NCG-PG11.B.B | NCG-PG11.B.G |
| PG13.5 | 6-12 | 20.4 | 9 | 27 | 24 | 100 | NCG-PG13.A.B | NCG-PG13.A.G |
| PG13.5 | 5-9 | 20.4 | 9 | 27 | 24 | 100 | NCG-PG13.B.B | NCG-PG13.B.G |
| PG16 | 8-14 | 22.5 | 10 | 28 | 27 | 50 | NCG-PG16.A.B | NCG-PG16.A.G |
| PG16 | 7-12 | 22.5 | 10 | 28 | 27 | 50 | NCG-PG16.B.B | NCG-PG16.B.G |
| PG21 | 13-18 | 28.3 | 11 | 31 | 33 | 50 | NCG-PG21.A.B | NCG-PG21.A.G |
| PG21 | 9-16 | 28.3 | 11 | 31 | 33 | 50 | NCG-PG21.B.B | NCG-PG21.B.G |
| PG29 | 18-25 | 37 | 11 | 39 | 42 | 25 | NCG-PG29.A.B | NCG-PG29.A.G |
| PG29 | 13-20 | 37 | 11 | 39 | 42 | 25 | NCG-PG29.B.B | NCG-PG29.B.G |
| PG36 | 22-32 | 47 | 13 | 48 | 53 | 20 | NCG-PG36.A.B | NCG-PG36.A.G |
| PG36 | 20-26 | 47 | 13 | 48 | 53 | 20 | NCG-PG36.B.B | NCG-PG36.B.G |
| PG42 | 32-38 | 54 | 13 | 49 | 60 | 16 | NCG-PG42.A.B | NCG-PG42.A.G |
| PG42 | 25-31 | 54 | 13 | 49 | 60 | 16 | NCG-PG42.B.B | NCG-PG42.B.G |
| PG48 | 37-44 | 59.3 | 14 | 49 | 65 | 12 | NCG-PG48.A.B | NCG-PG48.A.G |
| PG48 | 29-35 | 59.3 | 14 | 49 | 65 | 12 | NCG-PG48.B.B | NCG-PG48.B.G |

NCG-XX-L 尼龙加长电缆防水接头(连体式)

- 产品材质：PA6,(防火等级 UL94-V0);
- 橡胶件：耐候三元乙丙橡胶;
- 温度：-40℃—+100℃;
- 防护等级：IP68
- 颜色种类：黑色、灰色,选购时请确定 B (黑色),G (灰色)
- 产品特性:

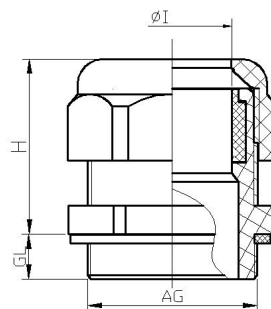

双螺纹，连接更顺畅，O型圈环槽，连接更紧密改进型护套，保护连接安全。

NCG-L M × 1.5 欧标公制螺纹

| 型号 | 卡口范围 | 螺纹外径 (AG) | 螺纹长度 (GL) | 高度 (H) | 扳手尺寸 | 包装单位 | 订货编号 (黑色) | 订货编号 (灰色) |
|---------|-------|-----------|-----------|--------|-------|------|---------------|---------------|
| M12×1.5 | 3-6.5 | 12 | 15 | 21 | 15 | 100 | NCG-M12-L.A.B | NCG-M12-L.A.G |
| M12×1.5 | 2-5 | 12 | 15 | 21 | 15 | 100 | NCG-M12-L.B.B | NCG-M12-L.B.G |
| M16×1.5 | 4-8 | 16 | 15 | 22 | 19 | 100 | NCG-M16-L.A.B | NCG-M16-L.A.G |
| M16×1.5 | 2-6 | 16 | 15 | 22 | 19 | 100 | NCG-M16-L.B.B | NCG-M16-L.B.G |
| M16×1.5 | 5-10 | 16 | 15 | 25 | 22 | 100 | NCG-M16-L.C.B | NCG-M16-L.C.G |
| M18×1.5 | 5-10 | 18 | 15 | 25 | 22 | 100 | NCG-M18-L.A.B | NCG-M18-L.A.G |
| M18×1.5 | 3-7 | 18 | 15 | 25 | 22 | 100 | NCG-M18-L.B.B | NCG-M18-L.B.G |
| M20×1.5 | 6-12 | 20 | 15 | 27 | 24 | 100 | NCG-M20-L.A.B | NCG-M20-L.A.G |
| M20×1.5 | 5-9 | 20 | 15 | 27 | 24 | 100 | NCG-M20-L.B.B | NCG-M20-L.B.G |
| M20×1.5 | 8-14 | 20 | 15 | 27 | 27 | 100 | NCG-M20-L.C.B | NCG-M20-L.C.G |
| M22×1.5 | 8-14 | 22 | 15 | 28 | 27 | 50 | NCG-M22-L.A.B | NCG-M22-L.A.G |
| M22×1.5 | 6-12 | 22 | 15 | 28 | 27 | 50 | NCG-M22-L.B.B | NCG-M22-L.B.G |
| M25×1.5 | 13-18 | 25 | 15 | 31 | 33 | 50 | NCG-M25-L.A.B | NCG-M25-L.A.G |
| M25×1.5 | 9-16 | 25 | 15 | 31 | 33 | 50 | NCG-M25-L.B.B | NCG-M25-L.B.G |
| M32×1.5 | 18-25 | 32 | 15 | 39 | 42 | 25 | NCG-M32-L.A.B | NCG-M32-L.A.G |
| M32×1.5 | 13-20 | 32 | 15 | 39 | 42 | 25 | NCG-M32-L.B.B | NCG-M32-L.B.G |
| M40×1.5 | 22-32 | 40 | 18 | 48 | 53 | 20 | NCG-M40-L.A.B | NCG-M40-L.A.G |
| M40×1.5 | 20-26 | 40 | 18 | 48 | 53 | 20 | NCG-M40-L.B.B | NCG-M40-L.B.G |
| M50×1.5 | 32-38 | 50 | 18 | 49 | 60 | 16 | NCG-M50-L.A.B | NCG-M50-L.A.G |
| M50×1.5 | 25-31 | 50 | 18 | 49 | 60 | 16 | NCG-M50-L.B.B | NCG-M50-L.B.G |
| M63×1.5 | 37-44 | 63 | 18 | 49 | 65/68 | 12 | NCG-M63-L.A.B | NCG-M63-L.A.G |
| M63×1.5 | 29-35 | 63 | 18 | 49 | 65/68 | 12 | NCG-M63-L.B.B | NCG-M63-L.B.G |

NCG-XX-L 尼龙加长电缆防水接头(连体式)

- 产品材质：PA6,(防火等级 UL94-V0);
- 橡胶件：耐候三元乙丙橡胶;
- 温度：-40℃—+100℃;
- 防护等级：IP68
- 颜色种类：黑色、灰色,选购时请确定 B (黑色),G (灰色)
- 产品特性:

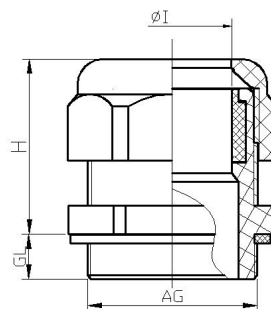

双螺纹，连接更顺畅，O型圈环槽，连接更紧密改进型护套，保护连接安全。

NCG-L PG 德制螺纹

| 型号 | 卡口范围 | 螺纹外径 (AG) | 螺纹长度 (GL) | 高度 (H) | 扳手尺寸 | 包装单位 | 订货编号 (黑色) | 订货编号 (灰色) |
|--------|-------|-----------|-----------|--------|------|------|----------------|----------------|
| PG7 | 3-6.5 | 12.5 | 15 | 21 | 15 | 100 | NCG-PG7-L.A.B | NCG-PG7-L.A.G |
| PG7 | 2-5 | 12.5 | 15 | 21 | 15 | 100 | NCG-PG7-L.B.B | NCG-PG7-L.B.G |
| PG9 | 4-8 | 15.2 | 15 | 22 | 19 | 100 | NCG-PG9-L.A.B | NCG-PG9-L.A.G |
| PG9 | 2-6 | 15.2 | 15 | 22 | 19 | 100 | NCG-PG9-L.B.B | NCG-PG9-L.B.G |
| PG11 | 5-10 | 18.6 | 15 | 25 | 22 | 100 | NCG-PG11-L.A.B | NCG-PG11-L.A.G |
| PG11 | 3-7 | 18.6 | 15 | 25 | 22 | 100 | NCG-PG11-L.B.B | NCG-PG11-L.B.G |
| PG13.5 | 6-12 | 20.4 | 15 | 27 | 24 | 100 | NCG-PG13-L.A.B | NCG-PG13-L.A.G |
| PG13.5 | 5-9 | 20.4 | 15 | 27 | 24 | 100 | NCG-PG13-L.B.B | NCG-PG13-L.B.G |
| PG16 | 8-14 | 22.5 | 15 | 28 | 27 | 50 | NCG-PG16-L.A.B | NCG-PG16-L.A.G |
| PG16 | 7-12 | 22.5 | 15 | 28 | 27 | 50 | NCG-PG16-L.B.B | NCG-PG16-L.B.G |
| PG21 | 13-18 | 28.3 | 15 | 31 | 33 | 50 | NCG-PG21-L.A.B | NCG-PG21-L.A.G |
| PG21 | 9-16 | 28.3 | 15 | 31 | 33 | 50 | NCG-PG21-L.B.B | NCG-PG21-L.B.G |
| PG29 | 18-25 | 37 | 15 | 39 | 42 | 25 | NCG-PG29-L.A.B | NCG-PG29-L.A.G |
| PG29 | 13-20 | 37 | 15 | 39 | 42 | 25 | NCG-PG29-L.B.B | NCG-PG29-L.B.G |
| PG36 | 22-32 | 47 | 18 | 48 | 53 | 20 | NCG-PG36-L.A.B | NCG-PG36-L.A.G |
| PG36 | 20-26 | 47 | 18 | 48 | 53 | 20 | NCG-PG36-L.B.B | NCG-PG36-L.B.G |
| PG42 | 32-38 | 54 | 18 | 49 | 60 | 16 | NCG-PG42-L.A.B | NCG-PG42-L.A.G |
| PG42 | 25-31 | 54 | 18 | 49 | 60 | 16 | NCG-PG42-L.B.B | NCG-PG42-L.B.G |
| PG48 | 37-44 | 59.3 | 18 | 49 | 65 | 12 | NCG-PG48-L.A.B | NCG-PG48-L.A.G |
| PG48 | 29-35 | 59.3 | 18 | 49 | 65 | 12 | NCG-PG48-L.B.B | NCG-PG48-L.B.G |

NCGB 尼龙电缆防水接头(分体式)

- 产品材质：PA6,(防火等级 UL94-V2), 可定制 V0 等级尼龙原料;
- 橡胶件：耐候三元乙丙橡胶;
- 温度：-40℃—+100℃;
- 颜色种类：黑色、灰色,选购时请确定 B (黑色),G (灰色)
- 产品特性：
特殊的夹紧设计，能够满足高密封防水要求，抗拉力能力强，
达到防水、防尘、抗酸碱、油污；

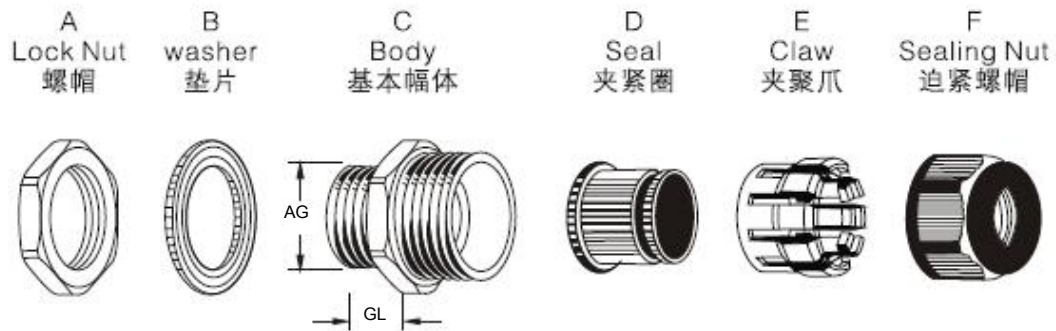
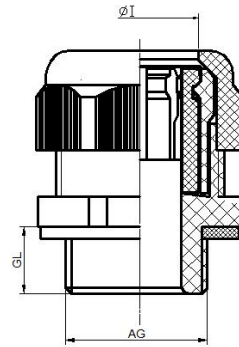

NCGB 尼龙电缆防水接头(分体式)

- 产品材质：PA6,(防火等级 UL94-V2), 可定制 V0 等级尼龙原料;
- 橡胶件：耐候三元乙丙橡胶;
- 温度：-40℃—+100℃;
- 颜色种类：黑色、灰色,选购时请确定 B (黑色) ,G (灰色)
- 产品特性:

特殊的夹紧设计，能够满足高密封防水要求，抗拉力能力强，达到防水、防尘、抗酸碱、油污；

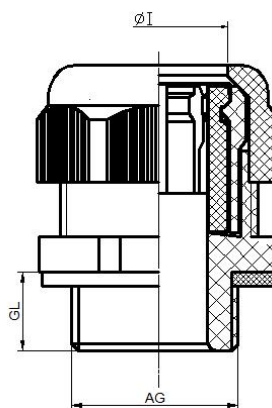

NCGB-M 公制螺纹

| 螺牙规格 Thread | 编号(黑色) Item.No. | 编号(灰白) Item.No. | 电缆范围 CableRange ϕI (mm) | 螺纹外径 ThreadO.D AG(mm) | 螺纹长度 ThreadLength GL(mm) | 扳手径 SpannerSize A&F(mm) | 包装 Std.Pkg (pcs) |
|----------------|--------------------|--------------------|-------------------------------------|-----------------------------|--------------------------------|-------------------------------|------------------------|
| M12 x 1.5 | NCGB-M12-5.5.B | NCGB-M12-5.5.G | 3-5.5 | 12 | 8.5 | 18/19 | 50 |
| M12 x 1.5 | NCGB-M12-8.B | NCGB-M12-8.G | 4.5-8 | 12 | 8.5 | 18/19 | 50 |
| M16 x 1.5 | NCGB-M16S-5.5.B | NCGB-M16S-5.5.G | 3-5.5 | 16 | 10 | 22/19 | 50 |
| M16 x 1.5 | NCGB-M16-10.B | NCGB-M16-10.G | 6-10 | 16 | 10 | 22/22 | 50 |
| M16 x 1.5 | NCGB-M16L-10.B | NCGB-M16L-10.G | 6-10 | 16 | 15 | 22/22 | 50 |
| M20 x 1.5 | NCGB-M20S-9.B | NCGB-M20S-9.G | 5-9 | 20 | 10 | 24/24 | 50 |
| M20 x 1.5 | NCGB-M20S-12.B | NCGB-M20S-12.G | 6-12 | 20 | 10 | 24/24 | 50 |
| M20 x 1.5 | NCGB-M20L-11.B | NCGB-M20L-12.G | 6-12 | 20 | 15 | 27/27 | 50 |
| M20 x 1.5 | NCGB-M20-14.B | NCGB-M20-14.G | 9-14 | 20 | 10 | 27/27 | 50 |
| M20 x 1.5 | NCGB-M20L-14.B | NCGB-M20L-14.G | 9-14 | 20 | 15 | 27/27 | 50 |
| M22 x 1.5 | NCGB-M22-11.B | NCGB-M22-11.G | 6-11 | 22 | 10 | 27/27 | 50 |
| M22 x 1.5 | NCGB-M22-14.B | NCGB-M22-14.G | 9-14 | 22 | 10 | 27/27 | 50 |
| M25 x 1.5 | NCGB-M25-16.B | NCGB-M25-16.G | 10-16 | 25 | 10 | 33/33 | 50 |
| M25 x 1.5 | NCGB-M25L-16.B | NCGB-M25L-16.G | 10-16 | 25 | 15 | 33/33 | 50 |
| M25 x 1.5 | NCGB-M25-18.B | NCGB-M25-18.G | 13-18 | 25 | 10 | 33/33 | 50 |
| M25 x 1.5 | NCGB-M25L-18.B | NCGB-M25L-18.G | 13-18 | 25 | 15 | 33/33 | 50 |
| M32 x 1.5 | NCGB-M32-22.B | NCGB-M32-22.G | 15-22 | 32 | 15 | 41/42 | 20 |
| M32 x 1.5 | NCGB-M32-25.B | NCGB-M32-25.G | 18-25 | 32 | 15 | 41/42 | 20 |
| M40 x 1.5 | NCGB-M40-26.B | NCGB-M40-26.G | 20-26 | 40 | 20 | 50/52 | 10 |
| M40 x 1.5 | NCGB-M40-31.B | NCGB-M40-31.G | 24-31 | 40 | 20 | 50/52 | 10 |
| M50 x 1.5 | NCGB-M50-33.B | NCGB-M50-33.G | 25-33 | 50 | 22 | 62/62 | 10 |
| M50 x 1.5 | NCGB-M50-41.B | NCGB-M50-41.G | 31-41 | 50 | 22 | 62/62 | 10 |
| M63 x 1.5 | NCGB-M63-46.B | NCGB-M63-46.G | 39-46 | 63 | 25 | 75/75 | 10 |
| M63 x 1.5 | NCGB-M63-51.B | NCGB-M63-51.G | 44-51 | 63 | 25 | 75/75 | 10 |
| M75 x 2.0 | NCGB-M75-60.B | NCGB-M75-60.G | 50-60 | 75 | 25 | 92/92 | 1 |
| M75 x 2.0 | NCGB-M75-66.B | NCGB-M75-66.G | 56-66 | 75 | 25 | 92/92 | 1 |
| M90 x 2.0 | NCGB-M90-68.B | NCGB-M90-68.G | 58-68 | 90 | 25 | 110/110 | 1 |
| M90 x 2.0 | NCGB-M90-77.B | NCGB-M90-77.G | 66-77 | 90 | 25 | 110/110 | 1 |

NCGB 尼龙电缆防水接头(分体式)

- 产品材质：PA6,(防火等级 UL94-V2), 可定制 V0 等级尼龙原料;
- 橡胶件：耐候三元乙丙橡胶;
- 温度：-40℃—+100℃;
- 颜色种类：黑色、灰色,选购时请确定 B (黑色),G (灰色)
- 产品特性：
特殊的夹紧设计，能够满足高密封防水要求，抗拉力能力强，
达到防水、防尘、抗酸碱、油污；

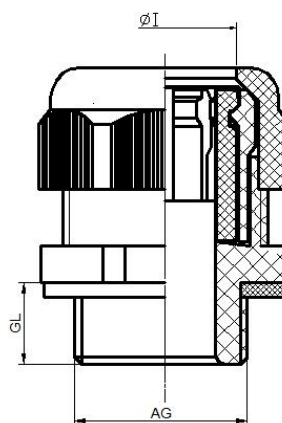

NCGB-PG 德制螺纹

| 螺牙规格 Thread | 编号(黑色) Item.No. | 编号(灰白) Item.No. | 电缆范围 CableRange ΦI (mm) | 螺纹外径 ThreadO.D AG(mm) | 螺纹长度 ThreadLength GL(mm) | 扳手径 SpannerSize A&F(mm) | 包装 Std.Pkg (pcs) |
|----------------|--------------------|--------------------|-------------------------------------|-----------------------------|--------------------------------|-------------------------------|------------------------|
| PG7 | NCGB-PG7-5.5.B | NCGB-PG7-5.5.G | 3-5.5 | 12.5 | 8 | 17/19 | 50 |
| PG7 | NCGB-PG7-8.B | NCGB-PG7-8.G | 4.5-8 | 12.5 | 8 | 17/19 | 50 |
| PG9 | NCGB-PG9-5.5.B | NCGB-PG9-5.5.G | 3-5.5 | 15.2 | 8.2 | 22/19 | 50 |
| PG9 | NCGB-PG9-8.B | NCGB-PG9-8.G | 4.5-8 | 15.2 | 8.2 | 22/19 | 50 |
| PG11 | NCGB-PG11-7.B | NCGB-PG11-7.G | 4-7 | 18.6 | 10 | 24/22 | 50 |
| PG11 | NCGB-PG11-10.B | NCGB-PG11-10.G | 6-10 | 18.6 | 10 | 24/22 | 50 |
| PG13.5 | NCGB-PG13.5-9.B | NCGB-PG13.5-9.G | 5-9 | 20.4 | 10 | 27/24 | 50 |
| PG13.5 | NCGB-PG13.5-12.B | NCGB-PG13.5-12.G | 7-12 | 20.4 | 10 | 27/24 | 50 |
| PG13.5 | NCGB-PG13.5-11.B | NCGB-PG13.5-11.G | 6-11 | 20.4 | 10.8 | 27/27 | 50 |
| PG13.5 | NCGB-PG13.5-14.B | NCGB-PG13.5-14.G | 9-14 | 20.4 | 10.8 | 27/27 | 50 |
| PG16 | NCGB-PG16-11.B | NCGB-PG16-11.G | 6-11 | 22.5 | 10.8 | 30/27 | 50 |
| PG16 | NCGB-PG16-14.B | NCGB-PG16-14.G | 9-14 | 22.5 | 10.8 | 30/27 | 50 |
| PG16 | NCGB-PG16-15.B | NCGB-PG16-15.G | 10-15 | 22.5 | 12 | 30/33 | 50 |
| PG16 | NCGB-PG16-17.B | NCGB-PG16-17.G | 13-17 | 22.5 | 12 | 30/33 | 50 |
| PG21 | NCGB-PG21-16.B | NCGB-PG21-16.G | 10-16 | 28.3 | 12 | 36/33 | 50 |
| PG21 | NCGB-PG21-18.B | NCGB-PG21-18.G | 13-18 | 28.3 | 12 | 36/33 | 50 |
| PG29 | NCGB-PG29-22.B | NCGB-PG29-22.G | 15-22 | 37 | 12 | 46/41 | 20 |
| PG29 | NCGB-PG29-24.B | NCGB-PG29-24.G | 18-25 | 37 | 12 | 46/41 | 20 |
| PG36 | NCGB-PG36-26.B | NCGB-PG36-26.G | 20-26 | 47 | 14 | 57/52 | 10 |
| PG36 | NCGB-PG36-31.B | NCGB-PG36-31.G | 24-31 | 47 | 14 | 57/52 | 10 |
| PG42 | NCGB-PG42-33.B | NCGB-PG42-33.G | 25-33 | 54 | 15 | 64/62 | 10 |
| PG42 | NCGB-PG42-41.B | NCGB-PG42-41.G | 31-41 | 54 | 15 | 64/62 | 10 |

NCGB 尼龙电缆防水接头(分体式)

- 产品材质：PA6,(防火等级 UL94-V2), 可定制 V0 等级尼龙原料;
- 橡胶件：耐候三元乙丙橡胶;
- 温度：-40℃—+100℃;
- 颜色种类：黑色、灰色,选购时请确定 B (黑色),G (灰色)
- 产品特性：
特殊的夹紧设计，能够满足高密封防水要求，抗拉力能力强，
达到防水、防尘、抗酸碱、油污；

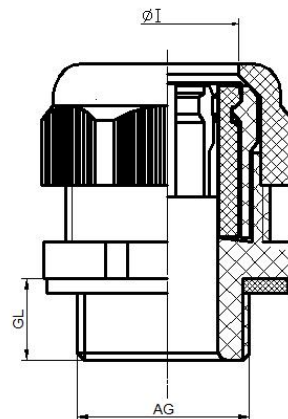

NCGB-G 管制螺纹

| 螺牙规格 Thread | 编号(黑色) Item.No. | 编号(灰白) Item.No. | 电缆范围 CableRange Φl (mm) | 螺纹外径 ThreadO.D AG(mm) | 螺纹长度 ThreadLength GL(mm) | 扳手径 SpannerSize A&F(mm) | 包装 Std.Pkg (pcs) |
|----------------|--------------------|--------------------|-------------------------------|-----------------------------|--------------------------------|-------------------------------|------------------------|
| G 1/4" | NCGB-G 1/4-5.5.B | NCGB-G 1/4-5.5.G | 3-5.5 | 13.157 | 8 | 19/19 | 50 |
| G 1/4" | NCGB-G 1/4-8.B | NCGB-G 1/4-8.G | 4-5-8 | 13.157 | 8 | 19/19 | 50 |
| G 3/8" | NCGB-G 3/8L-7.B | NCGB-G 3/8L-7.G | 4-7 | 16.662 | 15 | 22/22 | 50 |
| G 3/8" | NCGB-G 3/8L-10.B | NCGB-G 3/8L-10.G | 6-10 | 16.662 | 15 | 22/22 | 50 |
| G 1/2" | NCGB-G 1/2L-11.B | NCGB-G 1/2L-11.G | 6-11 | 20.955 | 15 | 27/24 | 50 |
| G 1/2" | NCGB-G 1/2L-14.B | NCGB-G 1/2L-14.G | 9-14 | 20.955 | 15 | 27/24 | 50 |
| G 3/4" | NCGB-G 3/4L-16.B | NCGB-G 3/4L-16.G | 10-16 | 26.441 | 15 | 36/33 | 50 |
| G 3/4" | NCGB-G 3/4L-18.B | NCGB-G 3/4L-18.G | 13-18 | 26.441 | 15 | 36/33 | 50 |
| G 1" | NCGB-G 1L-22.B | NCGB-G 1L-22.G | 15-22 | 33.249 | 15 | 46/41 | 20 |
| G 1" | NCGB-G 1L-24.B | NCGB-G 1L-24.G | 18-25 | 33.249 | 15 | 46/41 | 20 |
| G 1 1/4" | NCGB-G 1 1/4L-26.B | NCGB-G 1 1/4L-26.G | 20-26 | 41.91 | 16 | 57/52 | 10 |
| G 1 1/4" | NCGB-G 1 1/4L-31.B | NCGB-G 1 1/4L-31.G | 24-31 | 41.91 | 16 | 57/52 | 10 |
| G 1 1/2" | NCGB-G 1 1/2L-33.B | NCGB-G 1 1/2L-33.G | 25-33 | 48 | 22 | 60/62 | 10 |
| G 1 1/2" | NCGB-G 1 1/2L-41.B | NCGB-G 1 1/2L-41.G | 31-41 | 48 | 22 | 60/62 | 10 |
| G 2" | NCGB-G 2L-46.B | NCGB-G 2L-46.G | 39-46 | 60 | 25 | 75/75 | 10 |
| G 2" | NCGB-G 2L-51.B | NCGB-G 2L-51.G | 44-51 | 60 | 25 | 75/75 | 10 |

MCGB-金属电缆防水接头(分体式)

- 产品材质 黄铜镀镍 ,内部芯套为 PA66,(防火等级 UL94-V2);
- 橡胶件: 三元乙丙橡胶;
- 温度: -40°C — $+100^{\circ}\text{C}$;
- 产品特性:

特殊的夹紧设计,能够满足高密封防水要求,抗拉力能力强,达到防水、防尘、抗酸碱、油污

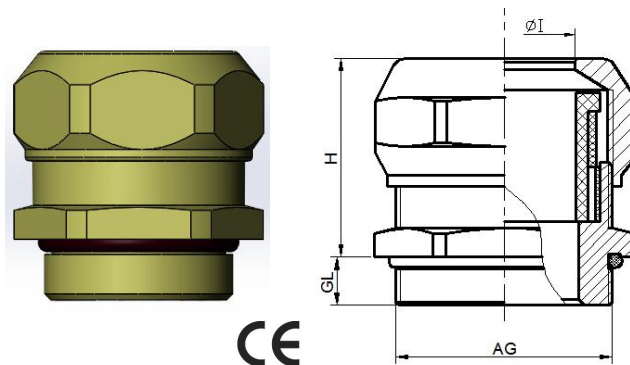

MCGB-GM、M 制螺纹 标准规格

| 螺纹规格 | 订货编号 | GL | AG | Φ I | 扳手尺寸 | 包装 |
|--------------|--------------|----|----|-------|-------|----|
| MCGB-M12X1.5 | 3001.012.009 | 6 | 12 | 3-7 | 14 | 50 |
| MCGB-M14X1.5 | 3001.014.009 | 6 | 14 | 3-7 | 14/16 | 50 |
| MCGB-M16X1.5 | 3001.016.009 | 7 | 16 | 4-8 | 18 | 50 |
| MCGB-M18X1.5 | 3001.018.009 | 7 | 18 | 5-10 | 20 | 50 |
| MCGB-M20X1.5 | 3001.020.009 | 8 | 20 | 6-12 | 22 | 50 |
| MCGB-M22X1.5 | 3001.022.009 | 8 | 22 | 10-14 | 24 | 50 |
| MCGB-M24X1.5 | 3001.020.009 | 8 | 20 | 10-14 | 24/27 | 50 |
| MCGB-M25X1.5 | 3001.025.019 | 8 | 25 | 10-14 | 24/27 | 25 |
| MCGB-M27X2.0 | 3001.027.009 | 8 | 27 | 13-18 | 30 | 25 |
| MCGB-M30X2.0 | 3001.030.009 | 8 | 30 | 13-18 | 28/34 | 20 |
| MCGB-M32X1.5 | 3001.032.009 | 8 | 32 | 15-22 | 34 | 20 |
| MCGB-M33X2.0 | 3001.033.009 | 9 | 33 | 15-22 | 34/36 | 20 |
| MCGB-M36X2.0 | 3001.036.009 | 9 | 36 | 18-25 | 40 | 20 |
| MCGB-M40X1.5 | 3001.040.009 | 9 | 40 | 22-28 | 45 | 10 |
| MCGB-M42X2.0 | 3001.042.009 | 9 | 42 | 22-28 | 45 | 10 |
| MCGB-M48X2.0 | 3001.048.009 | 10 | 48 | 25-32 | 50/52 | 10 |
| MCGB-M50X1.5 | 3001.050.009 | 10 | 50 | 25-32 | 50/56 | 10 |
| MCGB-M56X2.0 | 3001.056.009 | 12 | 56 | 32-38 | 58 | 5 |
| MCGB-M60X2.0 | 3001.060.009 | 12 | 60 | 37-44 | 64 | 5 |
| MCGB-M63X1.5 | 3001.063.009 | 12 | 63 | 37-44 | 64/68 | 1 |
| MCGB-M64X2.0 | 3001.064.009 | 12 | 64 | 37-44 | 64/68 | 1 |
| MCGB-M72X2.0 | 3001.072.009 | 15 | 72 | 46-52 | 76/78 | 1 |
| MCGB-M75X2.0 | 3001.075.009 | 15 | 75 | 46-52 | 76/78 | 1 |
| MCGB-M76X2.0 | 3001.076.009 | 15 | 76 | 46-52 | 76/78 | 1 |
| MCGB-M80X2.0 | 3001.080.009 | 17 | 80 | 55-60 | 88 | 1 |
| MCGB-M85X2.0 | 3001.085.009 | 17 | 85 | 65-70 | 98 | 1 |
| MCGB-M88X2.0 | 3001.088.009 | 18 | 88 | 65-70 | 98 | 1 |

MCGB-金属电缆防水接头(分体式)

- 产品材质：黄铜镀镍，内部芯套为 PA66,(防火等级 UL94-V2),;
- 橡胶件：三元乙丙橡胶;
- 温度：-40℃—+100℃;
- 产品特性:

特殊的夹紧设计，能够满足高密封防水要求，抗拉力能力强，达到防水、防尘、抗酸碱、油污

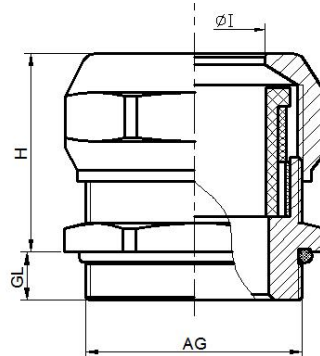
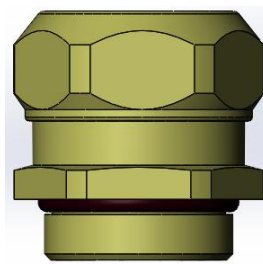

CE

MCGB-PG 制螺纹 标准规格

| 螺纹规格 | 订货编号 | GL | AG | ΦI | 扳手尺寸 | 包装 |
|-------------|--------------|----|------|----------|------|----|
| MCGB-PG7 | 3001.107.009 | 6 | 12.5 | 3-7 | 14 | 50 |
| MCGB-PG9 | 3001.109.009 | 7 | 15.2 | 4-8 | 17 | 50 |
| MCGB-PG11 | 3001.111.009 | 7 | 18.6 | 6-10 | 20 | 50 |
| MCGB-PG13.5 | 3001.135.009 | 8 | 20.4 | 8-12 | 22 | 50 |
| MCGB-PG16 | 3001.116.009 | 8 | 22.5 | 10-14 | 24 | 50 |
| MCGB-PG21 | 3001.121.009 | 8 | 28.3 | 13-18 | 30 | 25 |
| MCGB-PG29 | 3001.129.009 | 9 | 37.0 | 18-25 | 40 | 10 |
| MCGB-PG36 | 3001.136.009 | 10 | 47.0 | 25-32 | 50 | 10 |
| MCGB-PG42 | 3001.142.009 | 10 | 54.0 | 32-38 | 58 | 5 |
| MCGB-PG48 | 3001.148.009 | 12 | 59.3 | 37-44 | 64 | 5 |

MCGB-G 制螺纹 标准规格

| 螺纹规格 | 订货编号 | GL | AG | ΦI | 扳手尺寸 | 包装 |
|--------------|---------------|----|-------|----------|-------|----|
| MCGB-G1/4" | 3001.G14.009 | 6 | 13.15 | 3-7 | 14 | 50 |
| MCGB-G3/8" | 3001.G38.009 | 7 | 16.66 | 4-8 | 18 | 50 |
| MCGB-G1/2" | 3001.G12.009 | 8 | 20.99 | 8-12 | 22 | 50 |
| MCGB-G3/4" | 3001.G34.009 | 8 | 26.44 | 13-18 | 30 | 25 |
| MCGB-G1" | 3001.G1.009 | 9 | 33.25 | 15-22 | 36 | 10 |
| MCGB-G1 1/4" | 3001.G114.009 | 10 | 41.91 | 22-30 | 45 | 10 |
| MCGB-G1 1/2" | 3001.G112.009 | 10 | 47.80 | 25-32 | 50 | 5 |
| MCGB-G2" | 3001.G2.009 | 12 | 59.61 | 37-44 | 64 | 1 |
| MCGB-G2 1/2" | 3001.G212.009 | 15 | 75.18 | 43-52 | 76/78 | 1 |
| MCGB-G3" | 3001.G3.009 | 18 | 87.62 | 65-70 | 98 | 1 |

MCGB-金属电缆防水接头(分体式)

- 产品材质：黄铜镀镍，内部芯套为 PA66,(防火等级 UL94-V2),;
- 橡胶件：三元乙丙橡胶;
- 温度：-40℃—+100℃;
- 产品特性:

特殊的夹紧设计，能够满足高密封防水要求，抗拉力能力强，达到防水、防尘、抗酸碱、油污

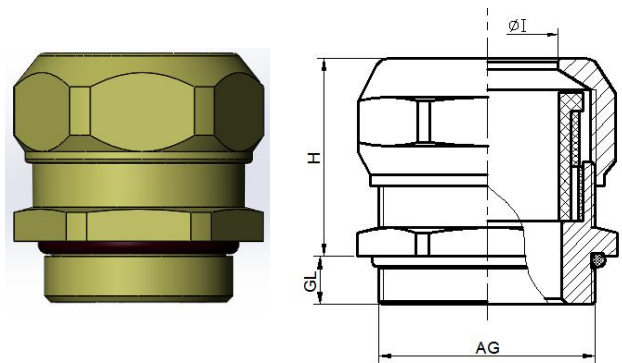

MCGB-NPT 制螺纹 标准规格

| 螺纹规格 | 订货编号 | GL | AG | Φ I | 扳手尺寸 | 包装 |
|----------------|---------------|----|-------|-------|------|----|
| MCGB-NPT1/4" | 3001.N14.009 | 6 | 13.61 | 3-7 | 14 | 50 |
| MCGB-NPT3/8" | 3001.N38.009 | 7 | 17.05 | 4-8 | 18 | 50 |
| MCGB-NPT1/2" | 3001.N12.009 | 8 | 21.22 | 8-12 | 22 | 50 |
| MCGB-NPT3/4" | 3001.N34.009 | 8 | 26.56 | 13-18 | 30 | 25 |
| MCGB-NPT1" | 3001.N1.009 | 9 | 33.22 | 15-22 | 36 | 10 |
| MCGB-NPT1 1/4" | 3001.N114.009 | 10 | 41.98 | 22-30 | 45 | 10 |
| MCGB-NPT1 1/2" | 3001.N112.009 | 10 | 48.05 | 25-32 | 50 | 5 |
| MCGB-NPT2" | 3001.N2.009 | 12 | 60.09 | 37-44 | 64 | 1 |
| MCGB-NPT2 1/2" | 3001.N212.009 | 15 | 72.69 | 43-52 | 78 | 1 |
| MCGB-NPT3" | 3001.N3.009 | 18 | 88.60 | 65-70 | 98 | 1 |



MCG-金属电缆防水接头(一体式)

- 产品材质：黄铜镀镍，内部芯套为 PA66,(防火等级 UL94-V2),;
- 橡胶件：三元乙丙橡胶;
- 温度：-40℃—+100℃;
- 产品特性:

特殊的夹紧设计，能够满足高密封防水要求，抗拉力能力强，达到防水、防尘、抗酸碱、油污

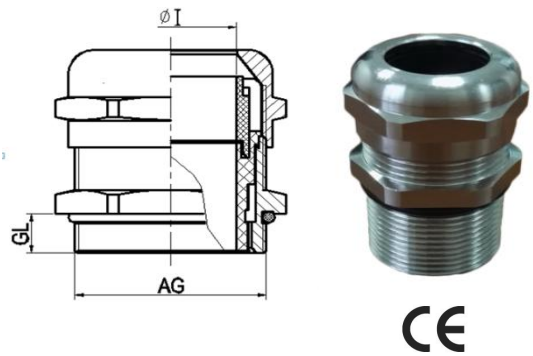

MCG-GM、M 制螺纹 标准规格

| 螺纹规格 | 订货编号 | GL | AG | Φ I | 扳手尺寸 | 包装 |
|-------------|--------------|----|----|-------|-------|----|
| MCG-M12X1.5 | 2001.012.009 | 6 | 12 | 3-7 | 14 | 50 |
| MCG-M14X1.5 | 2001.014.009 | 6 | 14 | 3-7 | 14/16 | 50 |
| MCG-M16X1.5 | 2001.016.009 | 7 | 16 | 4-8 | 18 | 50 |
| MCG-M18X1.5 | 2001.018.009 | 7 | 18 | 5-10 | 20 | 50 |
| MCG-M20X1.5 | 2001.020.009 | 8 | 20 | 6-12 | 22 | 50 |
| MCG-M22X1.5 | 2001.022.009 | 8 | 22 | 10-14 | 24 | 50 |
| MCG-M24X1.5 | 2001.020.009 | 8 | 20 | 10-14 | 24/27 | 50 |
| MCG-M25X1.5 | 2001.025.019 | 8 | 25 | 10-14 | 24/27 | 25 |
| MCG-M27X2.0 | 2001.027.009 | 8 | 27 | 13-18 | 30 | 25 |
| MCG-M30X2.0 | 2001.030.009 | 8 | 30 | 13-18 | 28/34 | 20 |
| MCG-M32X1.5 | 2001.032.009 | 8 | 32 | 15-22 | 34 | 20 |
| MCG-M33X2.0 | 2001.033.009 | 9 | 33 | 15-22 | 34/36 | 20 |
| MCG-M36X2.0 | 2001.036.009 | 9 | 36 | 18-25 | 40 | 20 |
| MCG-M40X1.5 | 2001.040.009 | 9 | 40 | 22-28 | 45 | 10 |
| MCG-M42X2.0 | 2001.042.009 | 9 | 42 | 22-28 | 45 | 10 |
| MCG-M48X2.0 | 2001.048.009 | 10 | 48 | 25-32 | 50/52 | 10 |
| MCG-M50X1.5 | 2001.050.009 | 10 | 50 | 25-32 | 50/56 | 10 |
| MCG-M56X2.0 | 2001.056.009 | 12 | 56 | 32-38 | 58 | 5 |
| MCG-M60X2.0 | 2001.060.009 | 12 | 60 | 37-44 | 64 | 5 |
| MCG-M63X1.5 | 2001.063.009 | 12 | 63 | 37-44 | 64/68 | 1 |
| MCG-M64X2.0 | 2001.064.009 | 12 | 64 | 37-44 | 64/68 | 1 |
| MCG-M72X2.0 | 2001.072.009 | 15 | 72 | 46-52 | 76/78 | 1 |
| MCG-M75X2.0 | 2001.075.009 | 15 | 75 | 46-52 | 76/78 | 1 |
| MCG-M76X2.0 | 2001.076.009 | 15 | 76 | 46-52 | 76/78 | 1 |
| MCG-M80X2.0 | 2001.080.009 | 17 | 80 | 55-60 | 88 | 1 |
| MCG-M85X2.0 | 2001.085.009 | 17 | 85 | 65-70 | 98 | 1 |
| MCG-M88X2.0 | 2001.088.009 | 18 | 88 | 65-70 | 98 | 1 |

MCG-金属电缆防水接头

- 产品材质：黄铜镀镍，内部芯套为 PA66,(防火等级 UL94-V2),;
- 橡胶件：三元乙丙橡胶;
- 温度：-40℃—+100℃;
- 产品特性:

特殊的夹紧设计，能够满足高密封防水要求，抗拉力能力强，达到防水、防尘、抗酸碱、油污

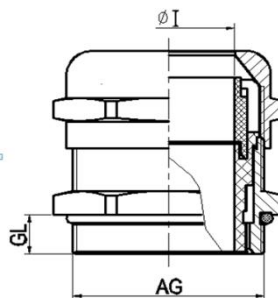

MCG-GM、M、制螺纹 非标规格

| 螺纹规格 | 订货编号 | GL | AG | Φ I | 扳手尺寸 | 包装 |
|-------------|--------------|----|----|-------|-------|----|
| MCG-M16X1.5 | 2001.016.029 | 7 | 16 | 5-10 | 20 | 50 |
| MCG-M20X1.5 | 2001.020.019 | 8 | 20 | 4-8 | 22 | 50 |
| MCG-M20X1.5 | 2001.020.029 | 8 | 20 | 6-12 | 22 | 50 |
| MCG-M20X1.5 | 2001.020.039 | 8 | 20 | 10-14 | 24 | 50 |
| MCG-M22X1.5 | 2001.022.019 | 8 | 22 | 8-12 | 22/24 | 50 |
| MCG-M25X1.5 | 2001.025.029 | 8 | 25 | 10-16 | 28 | 25 |
| MCG-M25X1.5 | 2001.025.009 | 8 | 25 | 13-18 | 30 | 25 |
| MCG-M27X2.0 | 2001.027.019 | 8 | 27 | 10-16 | 28/30 | 25 |
| MCG-M30X2.0 | 2001.030.019 | 8 | 30 | 10-16 | 28/34 | 10 |
| MCG-M30X2.0 | 2001.030.029 | 8 | 30 | 15-20 | 34 | 10 |
| MCG-M32X1.5 | 2001.032.019 | 9 | 32 | 13-18 | 30/34 | 10 |
| MCG-M32X1.5 | 2001.032.029 | 9 | 32 | 18-25 | 40 | 10 |
| MCG-M33X2.0 | 2001.033.009 | 9 | 33 | 15-22 | 34/36 | 10 |
| MCG-M36X2.0 | 2001.036.019 | 9 | 36 | 15-22 | 34/40 | 5 |
| MCG-M40X1.5 | 2001.040.019 | 9 | 40 | 18-25 | 40/43 | 5 |
| MCG-M40X1.5 | 2001.040.029 | 9 | 40 | 22-32 | 50 | 5 |
| MCG-M50X1.5 | 2001.050.029 | 12 | 50 | 32-38 | 58 | 5 |

**可定制非标规格，起订量 10 只以上!

MCG-金属电缆防水接头

- 产品材质：黄铜镀镍，内部芯套为 PA66,(防火等级 UL94-V2),;
- 橡胶件：三元乙丙橡胶;
- 温度：-40℃—+100℃;
- 产品特性:

特殊的夹紧设计，能够满足高密封防水要求，抗拉力能力强，达到防水、防尘、抗酸碱、油污

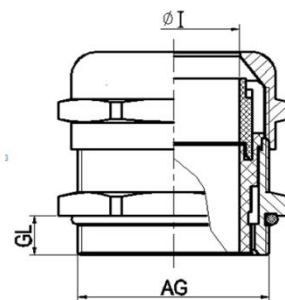

CE

MCG-PG 制螺纹 标准规格

| 螺纹规格 | 订货编号 | GL | AG | ΦI | 扳手尺寸 | 包装 |
|------------|--------------|----|------|-------|------|----|
| MCG-PG7 | 2001.107.009 | 6 | 12.5 | 3-7 | 14 | 50 |
| MCG-PG9 | 2001.109.009 | 7 | 15.2 | 4-8 | 17 | 50 |
| MCG-PG11 | 2001.111.009 | 7 | 18.6 | 6-10 | 20 | 50 |
| MCG-PG13.5 | 2001.135.009 | 8 | 20.4 | 8-12 | 22 | 50 |
| MCG-PG16 | 2001.116.009 | 8 | 22.5 | 10-14 | 24 | 50 |
| MCG-PG21 | 2001.121.009 | 8 | 28.3 | 13-18 | 30 | 25 |
| MCG-PG29 | 2001.129.009 | 9 | 37.0 | 18-25 | 40 | 10 |
| MCG-PG36 | 2001.136.009 | 10 | 47.0 | 25-32 | 50 | 10 |
| MCG-PG42 | 2001.142.009 | 10 | 54.0 | 32-38 | 58 | 5 |
| MCG-PG48 | 2001.148.009 | 12 | 59.3 | 37-44 | 64 | 5 |

MCG-PG 制螺纹 非标规格

| 螺纹规格 | 订货编号 | GL | AG | ΦI | 扳手尺寸 | 包装 |
|------------|--------------|----|------|-------|-------|----|
| MCG-PG9 | 2001.109.029 | 7 | 15.2 | 6-10 | 20 | 50 |
| MCG-PG13.5 | 2001.135.019 | 8 | 20.4 | 4-8 | 22 | 50 |
| MCG-PG13.5 | 2001.135.029 | 8 | 20.4 | 10-14 | 24 | 50 |
| MCG-PG16 | 2001.116.019 | 8 | 22.5 | 8-12 | 24 | 50 |
| MCG-PG21 | 2001.121.019 | 8 | 28.3 | 10-16 | 28/30 | 25 |
| MCG-PG36 | 2001.136.019 | 10 | 47.0 | 18-25 | 50 | 10 |

**可定制非标规格，起订量 10 只以上！

MCG-金属电缆防水接头

- 产品材质：黄铜镀镍，内部芯套为 PA66,(防火等级 UL94-V2),;
- 橡胶件：三元乙丙橡胶;
- 温度：-40℃—+100℃;
- 产品特性:

特殊的夹紧设计，能够满足高密封防水要求，抗拉力能力强，达到防水、防尘、抗酸碱、油污

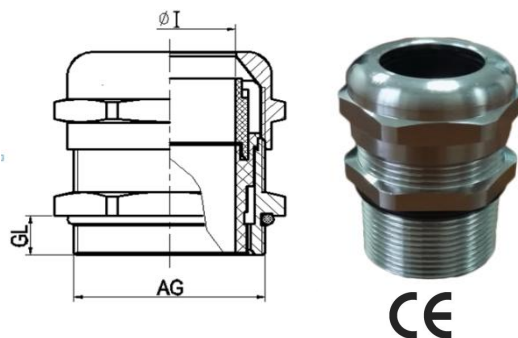

MCG-G 制螺纹 标准规格

| 螺纹规格 | 订货编号 | GL | AG | ΦI | 扳手尺寸 | 包装 |
|-------------|---------------|----|-------|-------|-------|----|
| MCG-G1/4" | 2001.G14.009 | 6 | 13.15 | 3-7 | 14 | 50 |
| MCG-G3/8" | 2001.G38.009 | 7 | 16.66 | 4-8 | 18 | 50 |
| MCG-G1/2" | 2001.G12.009 | 8 | 20.99 | 8-12 | 22 | 50 |
| MCG-G3/4" | 2001.G34.009 | 8 | 26.44 | 13-18 | 30 | 25 |
| MCG-G1" | 2001.G1.009 | 9 | 33.25 | 15-22 | 36 | 10 |
| MCG-G1 1/4" | 2001.G114.009 | 10 | 41.91 | 22-30 | 45 | 10 |
| MCG-G1 1/2" | 2001.G112.009 | 10 | 47.80 | 25-32 | 50 | 5 |
| MCG-G2" | 2001.G2.009 | 12 | 59.61 | 37-44 | 64 | 1 |
| MCG-G2 1/2" | 2001.G212.009 | 15 | 75.18 | 43-52 | 76/78 | 1 |
| MCG-G3" | 2001.G3.009 | 18 | 87.62 | 65-70 | 98 | 1 |

MCG-G 制螺纹 非标规格

| 螺纹规格 | 订货编号 | GL | AG | ΦI | 扳手尺寸 | 包装 |
|-------------|---------------|----|-------|-------|------|----|
| MCG-G3/8" | 2001.G38.029 | 7 | 16.66 | 6-10 | 20 | 50 |
| MCG-G1/2" | 2001.G12.019 | 8 | 20.99 | 4-8 | 22 | 50 |
| MCG-G1/2" | 2001.G12.029 | 8 | 20.99 | 10-14 | 24 | 50 |
| MCG-G1 1/2" | 2001.G112.019 | 10 | 47.80 | 18-25 | 50 | 10 |

**可定制非标规格，起订量 10 只以上！

MCG-金属电缆防水接头

- 产品材质：黄铜镀镍，内部芯套为 PA66,(防火等级 UL94-V2),;
- 橡胶件：三元乙丙橡胶;
- 温度：-40℃—+100℃;
- 产品特性:

特殊的夹紧设计，能够满足高密封防水要求，抗拉力能力强，达到防水、防尘、抗酸碱、油污

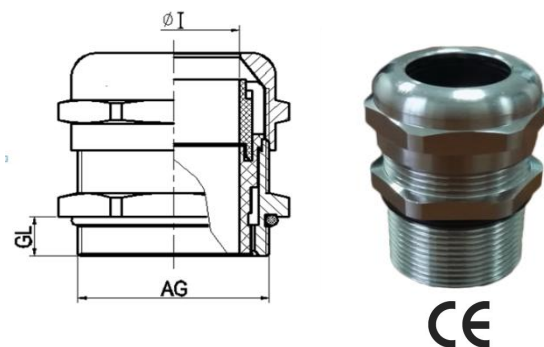

MCG-NPT 制螺纹 标准规格

| 螺纹规格 | 订货编号 | GL | AG | ΦI | 扳手尺寸 | 包装 |
|---------------|---------------|----|-------|-------|------|----|
| MCG-NPT1/4" | 2001.N14.009 | 6 | 13.61 | 3-7 | 14 | 50 |
| MCG-NPT3/8" | 2001.N38.009 | 7 | 17.05 | 4-8 | 18 | 50 |
| MCG-NPT1/2" | 2001.N12.009 | 8 | 21.22 | 8-12 | 22 | 50 |
| MCG-NPT3/4" | 2001.N34.009 | 8 | 26.56 | 13-18 | 30 | 25 |
| MCG-NPT1" | 2001.N1.009 | 9 | 33.22 | 15-22 | 36 | 10 |
| MCG-NPT1 1/4" | 2001.N114.009 | 10 | 41.98 | 22-30 | 45 | 10 |
| MCG-NPT1 1/2" | 2001.N112.009 | 10 | 48.05 | 25-32 | 50 | 5 |
| MCG-NPT2" | 2001.N2.009 | 12 | 60.09 | 37-44 | 64 | 1 |
| MCG-NPT2 1/2" | 2001.N212.009 | 15 | 72.69 | 43-52 | 78 | 1 |
| MCG-NPT3" | 2001.N3.009 | 18 | 88.60 | 65-70 | 98 | 1 |

SCG-不锈钢电缆防水接头

- 产品材质：不锈钢，内部芯套为 PA66,(防火等级 UL94-V2),;
- 橡胶件：三元乙丙橡胶;
- 温度：-40℃—+100℃;
- 产品特性:

特殊的夹紧设计，能够满足高密封防水要求，抗拉力能力强，达到防水、防尘、抗酸碱、油污

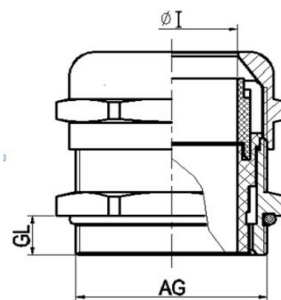

SCG-GM、M 制螺纹 标准规格

| 螺纹规格 | 订货编号 | GL | AG | Φ I | 扳手尺寸 | 包装 |
|-------------|--------------|----|----|-------|-------|----|
| SCG-M12X1.5 | 5001.012.009 | 6 | 12 | 3-7 | 14 | 50 |
| SCG-M14X1.5 | 5001.014.009 | 6 | 14 | 3-7 | 14/16 | 50 |
| SCG-M16X1.5 | 5001.016.009 | 7 | 16 | 4-8 | 17/18 | 50 |
| SCG-M18X1.5 | 5001.018.009 | 7 | 18 | 6-10 | 20 | 50 |
| SCG-M20X1.5 | 5001.020.009 | 8 | 20 | 8-12 | 22 | 50 |
| SCG-M22X1.5 | 5001.022.009 | 8 | 22 | 10-14 | 24 | 50 |
| SCG-M24X1.5 | 5001.020.009 | 8 | 20 | 10-14 | 24/27 | 50 |
| SCG-M25X1.5 | 5001.025.009 | 8 | 25 | 10-14 | 24/27 | 25 |
| SCG-M27X2.0 | 5001.027.009 | 8 | 27 | 13-18 | 30 | 25 |
| SCG-M30X2.0 | 5001.030.009 | 8 | 30 | 13-18 | 28/34 | 20 |
| SCG-M32X1.5 | 5001.032.009 | 9 | 32 | 15-22 | 34 | 20 |
| SCG-M33X2.0 | 5001.033.009 | 9 | 33 | 15-22 | 34/36 | 20 |
| SCG-M36X2.0 | 5001.036.009 | 9 | 36 | 18-25 | 40 | 20 |
| SCG-M40X1.5 | 5001.040.009 | 9 | 40 | 22-28 | 43 | 10 |
| SCG-M42X2.0 | 5001.042.009 | 9 | 42 | 22-28 | 43/45 | 10 |
| SCG-M48X2.0 | 5001.048.009 | 10 | 48 | 25-32 | 50/52 | 10 |
| SCG-M50X1.5 | 5001.050.009 | 10 | 50 | 25-32 | 50/56 | 10 |
| SCG-M56X2.0 | 5001.056.009 | 12 | 56 | 32-38 | 58 | 5 |
| SCG-M60X2.0 | 5001.060.009 | 12 | 60 | 37-44 | 64 | 5 |
| SCG-M63X1.5 | 5001.063.009 | 12 | 63 | 37-44 | 64/68 | 1 |
| SCG-M64X2.0 | 5001.064.009 | 12 | 64 | 37-44 | 64/68 | 1 |
| SCG-M72X2.0 | 5001.072.009 | 15 | 72 | 46-52 | 76/78 | 1 |
| SCG-M75X2.0 | 5001.075.009 | 15 | 75 | 46-52 | 76/78 | 1 |
| SCG-M76X2.0 | 5001.076.009 | 15 | 76 | 46-52 | 76/78 | 1 |
| SCG-M80X2.0 | 5001.080.009 | 17 | 80 | 55-60 | 88 | 1 |
| SCG-M85X2.0 | 5001.085.009 | 17 | 85 | 65-70 | 98 | 1 |
| SCG-M88X2.0 | 5001.088.009 | 18 | 88 | 65-70 | 98 | 1 |

SCG-不锈钢电缆防水接头

- 产品材质：不锈钢，内部芯套为 PA66,(防火等级 UL94-V2), ;
- 橡胶件：三元乙丙橡胶；
- 温度：-40℃—+100℃；
- 产品特性：

特殊的夹紧设计，能够满足高密封防水要求，抗拉力能力强，达到防水、防尘、抗酸碱、油污

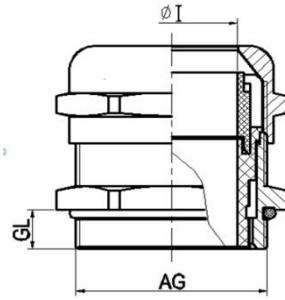

CE

SCG-GM、M、PG 制螺纹 非标规格

| 螺纹规格 | 订货编号 | GL | AG | Φ I | 扳手尺寸 | 包装 |
|-------------|--------------|----|----|-------|-------|----|
| SCG-M16X1.5 | 5001.016.029 | 7 | 16 | 6-10 | 20 | 50 |
| SCG-M20X1.5 | 5001.020.019 | 8 | 20 | 4-8 | 22 | 50 |
| SCG-M20X1.5 | 5001.020.029 | 8 | 20 | 6-10 | 20/22 | 50 |
| SCG-M20X1.5 | 5001.020.039 | 8 | 20 | 10-14 | 24 | 50 |
| SCG-M22X1.5 | 5001.022.019 | 8 | 22 | 8-12 | 22/24 | 50 |
| SCG-M25X1.5 | 5001.025.029 | 8 | 25 | 10-16 | 24/28 | 25 |
| SCG-M25X1.5 | 5001.025.039 | 8 | 25 | 13-18 | 30 | 25 |
| SCG-M27X2.0 | 5001.027.019 | 8 | 27 | 10-16 | 28/30 | 25 |
| SCG-M30X2.0 | 5001.030.019 | 8 | 30 | 10-16 | 28/34 | 10 |
| SCG-M30X2.0 | 5001.030.029 | 8 | 30 | 15-20 | 34 | 10 |
| SCG-M32X1.5 | 5001.032.019 | 9 | 32 | 13-18 | 30/34 | 10 |
| SCG-M32X1.5 | 5001.032.029 | 9 | 32 | 18-25 | 40 | 10 |
| SCG-M33X2.0 | 5001.033.009 | 9 | 33 | 15-22 | 34/36 | 10 |
| SCG-M36X2.0 | 5001.036.019 | 9 | 36 | 15-22 | 34/40 | 5 |
| SCG-M40X1.5 | 5001.040.019 | 9 | 40 | 18-25 | 40/43 | 5 |
| SCG-M40X1.5 | 5001.040.029 | 9 | 40 | 22-30 | 45 | 5 |
| SCG-M40X1.5 | 5001.040.039 | 9 | 40 | 22-32 | 50 | 5 |
| SCG-M50X1.5 | 5001.050.029 | 12 | 50 | 32-38 | 58 | 5 |

**可定制非标规格，起订量 10 只以上！

SCG-不锈钢电缆防水接头

- 产品材质：不锈钢，内部芯套为 PA66,(防火等级 UL94-V2), ;
- 橡胶件：三元乙丙橡胶；
- 温度：-40℃—+100℃；
- 产品特性：

特殊的夹紧设计，能够满足高密封防水要求，抗拉力能力强，达到防水、防尘、抗酸碱、油污

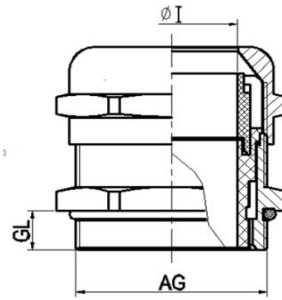

CE

SCG-PG 制螺纹 标准规格

| 螺纹规格 | 订货编号 | GL | AG | ΦI | 扳手尺寸 | 包装 |
|------------|--------------|----|------|-------|------|----|
| SCG-PG7 | 5001.107.009 | 6 | 12.5 | 3-7 | 14 | 50 |
| SCG-PG9 | 5001.109.009 | 7 | 15.2 | 4-8 | 17 | 50 |
| SCG-PG11 | 5001.111.009 | 7 | 18.6 | 6-10 | 20 | 50 |
| SCG-PG13.5 | 5001.135.009 | 8 | 20.4 | 8-12 | 22 | 50 |
| SCG-PG16 | 5001.116.009 | 8 | 22.5 | 10-14 | 24 | 50 |
| SCG-PG21 | 5001.121.009 | 8 | 28.3 | 13-18 | 30 | 25 |
| SCG-PG29 | 5001.129.009 | 9 | 37.0 | 18-25 | 40 | 10 |
| SCG-PG36 | 5001.136.009 | 10 | 47.0 | 25-32 | 50 | 10 |
| SCG-PG42 | 5001.142.009 | 10 | 54.0 | 32-38 | 58 | 5 |
| SCG-PG48 | 5001.148.009 | 12 | 59.3 | 37-44 | 64 | 5 |

SCG-PG 制螺纹 非标规格

| 螺纹规格 | 订货编号 | GL | AG | ΦI | 扳手尺寸 | 包装 |
|------------|--------------|----|------|-------|-------|----|
| SCG-PG9 | 5001.109.029 | 7 | 15.2 | 6-10 | 20 | 50 |
| SCG-PG13.5 | 5001.135.019 | 8 | 20.4 | 4-8 | 22 | 50 |
| SCG-PG13.5 | 5001.135.029 | 8 | 20.4 | 10-14 | 24 | 50 |
| SCG-PG16 | 5001.116.019 | 8 | 22.5 | 8-12 | 24 | 50 |
| SCG-PG21 | 5001.121.019 | 8 | 28.3 | 10-16 | 28/30 | 25 |
| SCG-PG36 | 5001.136.019 | 10 | 47.0 | 18-25 | 50 | 10 |

**可定制非标规格，起订量 10 只以上！

SCG-不锈钢电缆防水接头

- 产品材质：不锈钢，内部芯套为 PA66,(防火等级 UL94-V2), ;
- 橡胶件：三元乙丙橡胶；
- 温度：-40℃—+100℃；
- 产品特性：

特殊的夹紧设计，能够满足高密封防水要求，抗拉力能力强，达到防水、防尘、抗酸碱、油污

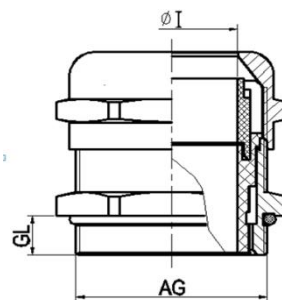

CE

SCG-G 制螺纹 标准规格

| 螺纹规格 | 订货编号 | GL | AG | ΦI | 扳手尺寸 | 包装 |
|-------------|---------------|----|-------|----------|-------|----|
| SCG-G1/4" | 5001.G14.009 | 6 | 13.15 | 3-7 | 14 | 50 |
| SCG-G3/8" | 5001.G38.009 | 7 | 16.66 | 4-8 | 17/18 | 50 |
| SCG-G1/2" | 5001.G12.009 | 8 | 20.99 | 8-12 | 22 | 50 |
| SCG-G3/4" | 5001.G34.009 | 8 | 26.44 | 13-18 | 30 | 25 |
| SCG-G1" | 5001.G1.009 | 9 | 33.25 | 15-22 | 34/36 | 10 |
| SCG-G1 1/4" | 5001.G114.009 | 10 | 41.91 | 22-30 | 43/45 | 10 |
| SCG-G1 1/2" | 5001.G112.009 | 10 | 47.80 | 25-32 | 50 | 5 |
| SCG-G2" | 5001.G2.009 | 12 | 59.61 | 37-44 | 64 | 1 |
| SCG-G2 1/2" | 5001.G212.009 | 15 | 75.18 | 43-52 | 76/78 | 1 |
| SCG-G3" | 5001.G3.009 | 18 | 87.62 | 65-70 | 98 | 1 |

SCG-G 制螺纹 非标规格

| 螺纹规格 | 订货编号 | GL | AG | ΦI | 扳手尺寸 | 包装 |
|-------------|---------------|----|-------|----------|------|----|
| SCG-G3/8" | 5001.G38.029 | 7 | 16.66 | 6-10 | 20 | 50 |
| SCG-G1/2" | 5001.G12.019 | 8 | 20.99 | 4-8 | 22 | 50 |
| SCG-G1/2" | 5001.G12.029 | 8 | 20.99 | 10-14 | 24 | 50 |
| SCG-G1 1/2" | 5001.G112.019 | 10 | 47.80 | 18-25 | 50 | 10 |

**可定制非标规格，起订量 10 只以上！

SCG-不锈钢电缆防水接头

- 产品材质：不锈钢，内部芯套为 PA66,(防火等级 UL94-V2), ;
- 橡胶件：三元乙丙橡胶;
- 温度：-40℃—+100℃;
- 产品特性:

特殊的夹紧设计，能够满足高密封防水要求，抗拉力能力强，达到防水、防尘、抗酸碱、油污

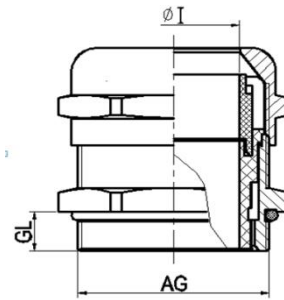

SCG-NPT 制螺纹 标准规格

| 螺纹规格 | 订货编号 | GL | AG | Φ I | 扳手尺寸 | 包装 |
|---------------|---------------|----|-------|-------|------|----|
| SCG-NPT1/4" | 5001.N14.009 | 6 | 13.61 | 3-7 | 14 | 50 |
| SCG-NPT3/8" | 5001.N38.009 | 7 | 17.05 | 4-8 | 18 | 50 |
| SCG-NPT1/2" | 5001.N12.009 | 8 | 21.22 | 8-12 | 22 | 50 |
| SCG-NPT3/4" | 5001.N34.009 | 8 | 26.56 | 13-18 | 30 | 25 |
| SCG-NPT1" | 5001.N1.009 | 9 | 33.22 | 15-22 | 36 | 10 |
| SCG-NPT1 1/4" | 5001.N114.009 | 10 | 41.98 | 22-30 | 45 | 10 |
| SCG-NPT1 1/2" | 5001.N112.009 | 10 | 48.05 | 25-32 | 50 | 5 |
| SCG-NPT2" | 5001.N2.009 | 12 | 60.09 | 37-44 | 64 | 1 |
| SCG-NPT2 1/2" | 5001.N212.009 | 15 | 72.69 | 43-52 | 78 | 1 |
| SCG-NPT3" | 5001.N3.009 | 18 | 88.60 | 65-70 | 98 | 1 |

MCG-EMV-金属卡爪式屏蔽接头

- 产品材质 :外部黄铜镀镍 ,内部芯套为 PA66,(防火等级 UL94-V2),
- 橡胶件: 三元乙丙橡胶;
- 温度: -40°C — $+100^{\circ}\text{C}$;
- 产品特性:
 - 1、特殊的夹紧设计,能够满足高密封防水要求,抗拉力能力强,达到防水、防尘、抗酸碱、油污
 - 2、满足屏蔽的需求

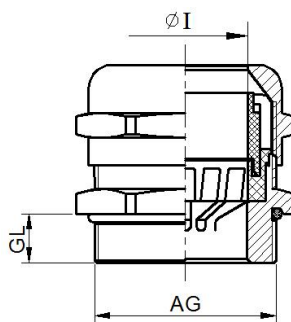

CE

MCG-EMV-公制螺纹

| 螺纹规格 | 订货编号 | GL | AG | ΦI | 扳手尺寸 | 包装 |
|---------|--------------|----|----|----------|------|----|
| M12X1.5 | 2201.012.009 | 5 | 12 | 4-8 | 20 | 50 |
| M16X1.5 | 2201.016.009 | 6 | 16 | 5-10 | 22 | 50 |
| M20X1.5 | 2201.020.009 | 7 | 20 | 10-14 | 26 | 50 |
| M25X1.5 | 2201.025.009 | 7 | 25 | 12-18 | 30 | 25 |
| M32X1.5 | 2201.032.009 | 8 | 32 | 17-24 | 38 | 20 |
| M40X1.5 | 2201.040.009 | 9 | 40 | 23-32 | 50 | 10 |
| M50X1.5 | 2201.050.009 | 9 | 50 | 31-40 | 60 | 10 |

MC

G-

EM

V-

PG

制螺纹

| 螺纹规格 | 订货编号 | GL | AG | ΦI | 扳手尺寸 | 包装 |
|--------|--------------|----|------|----------|------|----|
| PG7 | 2201.P07.009 | 5 | 12.5 | 4-8 | 20 | 50 |
| PG9 | 2201.P09.009 | 6 | 15.2 | 5-10 | 22 | 50 |
| PG11 | 2201.P11.009 | 6 | 18.6 | 5-10 | 22 | 50 |
| PG13.5 | 2201.P13.009 | 7 | 20.4 | 10-14 | 26 | 50 |
| PG16 | 2201.P16.009 | 7 | 22.5 | 10-14 | 26 | 50 |
| PG21 | 2201.P21.009 | 7 | 28.3 | 12-18 | 30 | 25 |
| PG29 | 2201.P29.009 | 8 | 37 | 17-24 | 40 | 20 |
| PG36 | 2201.P36.009 | 9 | 47 | 22-32 | 50 | 10 |
| PG42 | 2201.P42.009 | 9 | 54 | 31-40 | 60 | 10 |



NRP-尼龙圆闷盖

- 产品材质：尼龙塑料
- 橡胶件：三元乙丙橡胶；
- 温度：-40℃—+80℃；
- 产品特性：堵塞未使用的孔，达到防尘、防水的作用，

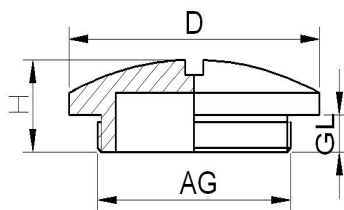

NRP-PG 德制螺纹

| 螺纹规格 | 编号及规格 | | 螺纹外径 AG mm | 螺纹长度 GL mm | 闷盖外径 D mm |
|--------|--------------|--------------|---------------|---------------|--------------|
| | 黑色 | 灰色 | | | |
| PG7 | NRP.PG7.B | NRP.PG7.G | 12.5 | 8 | 16.5 |
| PG9 | NRP.PG9.B | NRP.PG9.G | 15.2 | 8 | 19.2 |
| PG11 | NRP.PG11.B | NRP.PG11.G | 18.6 | 8 | 22.6 |
| PG13.5 | NRP.PG13.5.B | NRP.PG13.5.G | 20.4 | 9 | 24.4 |
| PG16 | NRP.PG16.B | NRP.PG16.G | 22.5 | 10 | 26.5 |
| PG21 | NRP.PG21.B | NRP.PG21.G | 28.3 | 10 | 32.3 |
| PG29 | NRP.PG29.B | NRP.PG29.G | 37 | 11 | 33 |
| PG36 | NRP.PG36.B | NRP.PG36.G | 47 | 11 | 53 |
| PG42 | NRP.P42.B | NRP.P42.G | 54 | 11 | 60 |
| PG48 | NRP.PG48.B | NRP.PG48.G | 59.3 | 11 | 65.3 |

NRP-M 公制螺纹

| 螺纹规格 | 编号及规格 | | 螺纹外径 AG mm | 螺纹长度 GL mm | 闷盖外径 D mm |
|---------|-----------|-----------|---------------|---------------|--------------|
| | 黑色 | 灰色 | | | |
| M12×1.5 | NRP.M12.B | NRP.M12.G | 12 | 8 | 16 |
| M16×1.5 | NRP.M16.B | NRP.M16.G | 16 | 8 | 20 |
| M18×1.5 | NRP.M18.B | NRP.M18.G | 18 | 8 | 23 |
| M20×1.5 | NRP.M20.B | NRP.M20.G | 20 | 9 | 25 |
| M22×1.5 | NRP.M22.B | NRP.M22.G | 22 | 10 | 27 |
| M24×1.5 | NRP.M24.B | NRP.M24.G | 24 | 10 | 29 |
| M25×1.5 | NRP.M25.B | NRP.M25.G | 25 | 11 | 30 |
| M27×1.5 | NRP.M27.B | NRP.M27.G | 27 | 11 | 33 |
| M30×1.5 | NRP.M30.B | NRP.M30.G | 30 | 11 | 35 |
| M32×1.5 | NRP.M32.B | NRP.M32.G | 32 | 11 | 39 |
| M36×1.5 | NRP.M36.B | NRP.M36.G | 36 | 11 | 44 |
| M40×1.5 | NRP.M40.B | NRP.M40.G | 40 | 13 | 46 |
| M48×1.5 | NRP.M48.B | NRP.M48.G | 48 | 13 | 55 |
| M50×1.5 | NRP.M50.B | NRP.M50.G | 50 | 15 | 57 |
| M63×1.5 | NRP.M63.B | NRP.M63.G | 63 | 15 | 70 |

MSP -金属六角闷盖

- 产品材质：黄铜镀镍
- 橡胶件：三元乙丙橡胶；
- 温度：-40℃—+100℃；
- 防护等级：IP68
- 产品特性：堵塞未使用的孔，达到防尘、防水的作用，

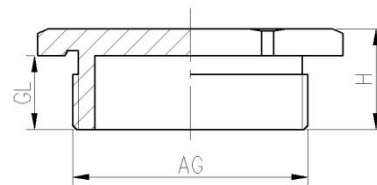

MSP-M 制螺纹 标准规格

| 螺纹规格 | 订货编号 | 螺纹外径 (AG) | 扳手尺寸 | 螺纹长度 (GL) | 总长度 (L) | 包装 |
|---------|--------------|--------------|------|--------------|------------|----|
| M10×1.5 | 7001.010.009 | 10 | 12 | 6 | 9 | 50 |
| M12×1.5 | 7001.012.009 | 12 | 14 | 6 | 9 | 50 |
| M16×1.5 | 7001.016.009 | 16 | 18 | 7 | 10 | 50 |
| M18×1.5 | 7001.018.009 | 18 | 20 | 7 | 10.5 | 50 |
| M20×1.5 | 7001.020.009 | 20 | 22 | 7 | 10.5 | 50 |
| M22×1.5 | 7001.022.009 | 22 | 24 | 7 | 10.5 | 50 |
| M24×1.5 | 7001.024.009 | 24 | 27 | 7 | 10.5 | 25 |
| M25×1.5 | 7001.025.009 | 25 | 28 | 7 | 10.5 | 25 |
| M27×1.5 | 7001.027.009 | 27 | 30 | 8 | 12 | 25 |
| M30×1.5 | 7001.030.009 | 30 | 34 | 8 | 12 | 25 |
| M32×1.5 | 7001.032.009 | 32 | 36 | 8 | 12 | 25 |
| M33×1.5 | 7001.033.009 | 33 | 36 | 8 | 12 | 25 |
| M36×1.5 | 7001.036.009 | 36 | 40 | 8 | 12 | 10 |
| M40×1.5 | 7001.040.009 | 40 | 45 | 9 | 14 | 5 |
| M48×1.5 | 7001.048.009 | 48 | 52 | 9 | 14 | 5 |
| M50×1.5 | 7001.050.009 | 50 | 55 | 9 | 14 | 5 |
| M56×1.5 | 7001.056.009 | 56 | 60 | 9 | 15 | 5 |
| M63×1.5 | 7001.063.009 | 63 | 70 | 10 | 16 | 1 |
| M64×1.5 | 7001.064.009 | 64 | 70 | 10 | 16 | 1 |

MSP-PG 德制螺纹 标准规格

| 螺纹规格 | 订货编号 | 螺纹外径 (AG) | 扳手尺寸 | 螺纹长度 (GL) | 总长度 (L) | 包装 |
|--------|--------------|--------------|------|--------------|------------|----|
| PG7 | 7001.107.009 | 12.5 | 15 | 6 | 9 | 50 |
| PG9 | 7001.109.009 | 15.2 | 18 | 7 | 10 | 50 |
| PG11 | 7001.111.009 | 18.6 | 21 | 7 | 10.5 | 50 |
| PG13.5 | 7001.135.009 | 20.4 | 23 | 7 | 10.5 | 50 |
| PG16 | 7001.116.009 | 22.5 | 26 | 7 | 10.5 | 50 |
| PG21 | 7001.121.009 | 28.3 | 32 | 7 | 11 | 50 |
| PG29 | 7001.129.009 | 37.0 | 40 | 8 | 12 | 25 |
| PG36 | 7001.136.009 | 47.0 | 50 | 9 | 14 | 10 |
| PG42 | 7001.142.009 | 54.0 | 58 | 9 | 14 | 5 |
| PG48 | 7001.148.009 | 59.3 | 65 | 10 | 16 | 5 |

MSP-G 管制螺纹 标准规格

| 螺纹规格 | 订货编号 | 螺纹外径 (AG) | 扳手尺寸 | 螺纹长度 (GL) | 总长度 (L) | 包装 |
|----------|---------------|--------------|------|--------------|------------|----|
| G 3/8" | 7001.G38.009 | 16.662 | 20 | 8 | 11.5 | 50 |
| G 1/2" | 7001.G12.009 | 20.995 | 24 | 8 | 11.5 | 50 |
| G 3/4" | 7001.G34.009 | 26.441 | 30 | 8 | 12 | 50 |
| G 1" | 7001.G1.009 | 33.249 | 38 | 9 | 13 | 50 |
| G 1 1/4" | 7001.G114.009 | 41.910 | 50 | 10 | 15 | 50 |
| G 1 1/2" | 7001.G112.009 | 47.803 | 52 | 10 | 15 | 50 |
| G 2" | 7001.G2.009 | 59.614 | 65 | 11 | 17 | 25 |
| G 2 1/2" | 7001.G212.009 | 75.814 | 80 | 11 | 17 | 10 |
| G 3" | 7001.G3.009 | 87.884 | 95 | 11 | 18.5 | 5 |

MSP-NPT 制螺纹 标准规格

| 螺纹规格 | 订货编号 | 螺纹外径 (AG) | 扳手尺寸 | 螺纹长度 (GL) | 总长度 (L) | 包装 |
|----------|---------------|--------------|------|--------------|------------|----|
| N 3/8" | 7001.N38.009 | 17.415 | 20 | 11 | 14.5 | 50 |
| N 1/2" | 7001.N12.009 | 21.336 | 23 | 13 | 16.5 | 50 |
| N 3/4" | 7001.N34.009 | 26.67 | 30 | 13 | 17 | 50 |
| N 1" | 7001.N1.009 | 33.44 | 38 | 16 | 20 | 50 |
| N 1 1/4" | 7001.N114.009 | 42.164 | 50 | 16 | 21 | 50 |
| N 1 1/2" | 7001.N112.009 | 48.26 | 52 | 18 | 23 | 50 |
| N 2" | 7001.N2.009 | 60.325 | 65 | 18 | 24 | 25 |
| N 2 1/2" | 7001.N212.009 | 73.025 | 80 | 22 | 28 | 10 |
| N 3" | 7001.N3.009 | 88.9 | 95 | 22 | 28 | 5 |

MRP-金属圆闷盖

- 产品材质：黄铜镀镍
- 橡胶件：三元乙丙橡胶；
- 温度：-40℃—+100℃；
- 产品特性：堵塞未使用的孔，达到防尘、防水的作用，

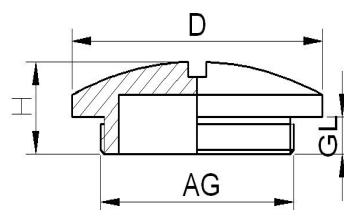

MRP-M 制螺纹 标准规格

| 螺纹规格 | 订货编号 | 螺纹外径 (AG) | 头部直径 (D) | 螺纹长度 (GL) | 总长度 (H) | 包装 |
|---------|--------------|--------------|-------------|--------------|------------|----|
| M10×1.5 | 7021.010.009 | 10 | 6 | 9 | 12 | 50 |
| M12×1.5 | 7021.012.009 | 12 | 6 | 9 | 14 | 50 |
| M16×1.5 | 7021.016.009 | 16 | 7 | 10 | 18 | 50 |
| M18×1.5 | 7021.018.009 | 18 | 7 | 10 | 21 | 50 |
| M20×1.5 | 7021.020.009 | 20 | 7 | 10 | 23 | 50 |
| M22×1.5 | 7021.022.009 | 22 | 7 | 10 | 25 | 50 |
| M24×1.5 | 7021.024.009 | 24 | 7 | 10 | 27 | 25 |
| M25×1.5 | 7021.025.009 | 25 | 7 | 10 | 28 | 25 |
| M27×1.5 | 7021.027.009 | 27 | 7 | 11 | 30 | 25 |
| M30×1.5 | 7021.030.009 | 30 | 7 | 11 | 33 | 25 |
| M32×1.5 | 7021.032.009 | 32 | 8 | 12 | 35 | 25 |
| M33×1.5 | 7021.033.009 | 33 | 8 | 12 | 36 | 25 |
| M36×1.5 | 7021.036.009 | 36 | 8 | 12 | 39 | 10 |
| M40×1.5 | 7021.040.009 | 40 | 9 | 15 | 44 | 5 |
| M42×1.5 | 7021.042.009 | 42 | 9 | 15 | 46 | 5 |
| M48×1.5 | 7021.048.009 | 48 | 9 | 15 | 52 | 5 |
| M50×1.5 | 7021.050.009 | 50 | 9 | 15 | 54 | 5 |
| M56×1.5 | 7021.056.009 | 56 | 9 | 15 | 60 | 1 |
| M63×1.5 | 7021.063.009 | 63 | 10 | 16 | 67 | 1 |
| M64×1.5 | 7021.064.009 | 64 | 10 | 16 | 68 | 1 |

MRP-PG 德制螺纹 标准规格

| 螺纹规格 | 订货编号 | 螺纹外径 (AG) | 头部直径 (D) | 螺纹长度 (GL) | 总长度 (L) | 包装 |
|--------|--------------|--------------|-------------|--------------|------------|----|
| PG7 | 7021.107.009 | 12.5 | 14 | 6 | 9 | 50 |
| PG9 | 7021.109.009 | 15.2 | 18 | 7 | 10 | 50 |
| PG11 | 7021.111.009 | 18.6 | 21 | 7 | 10 | 50 |
| PG13.5 | 7021.135.009 | 20.4 | 23 | 7 | 10 | 50 |
| PG16 | 7021.116.009 | 22.5 | 25 | 7 | 10 | 50 |
| PG21 | 7021.121.009 | 28.3 | 31 | 7 | 11 | 50 |
| PG29 | 7021.129.009 | 37.0 | 40 | 8 | 12 | 25 |
| PG36 | 7021.136.009 | 47.0 | 50 | 9 | 15 | 10 |
| PG42 | 7021.142.009 | 54.0 | 57 | 9 | 16 | 5 |
| PG48 | 7021.148.009 | 59.3 | 64 | 10 | 16 | 5 |



MJH-金属减缩环

- 产品材质：黄铜镀镍
- 橡胶件：三元乙丙橡胶；
- 温度：-40℃—+100℃；
- 防护等级：IP68

产品特性：螺纹缩减功能

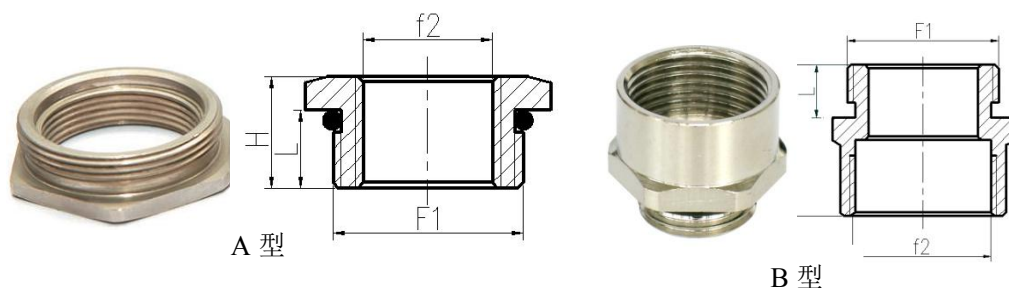

MJH-M 制螺纹 标准规格

| 螺纹规格 | 订货编号 | 外螺纹规格 | 内螺纹规格 | 扳手尺寸 (SW) | 螺纹长度 (L) | 总长度 (H) | 形式 |
|---------|--------------|---------|---------|--------------|-------------|---------|----|
| M16/M12 | 7071.016.012 | M16×1.5 | M12×1.5 | 18 | 8 | 12 | A |
| M20/M16 | 7071.020.016 | M20×1.5 | M16×1.5 | 24 | 9 | 13 | A |
| M25/M16 | 7071.025.016 | M25×1.5 | M16×1.5 | 30 | 11 | 16 | A |
| M25/M18 | 7071.025.018 | M25×1.5 | M18×1.5 | 30 | 11 | 16 | A |
| M25/M20 | 7071.025.020 | M25×1.5 | M20×1.5 | 30 | 11 | 16 | A |
| M32/M20 | 7071.032.020 | M32×1.5 | M20×1.5 | 36 | 11 | 16 | A |
| M32/M24 | 7071.032.024 | M32×1.5 | M24×1.5 | 36 | 11 | 16 | A |
| M32/M25 | 7071.032.025 | M32×1.5 | M25×1.5 | 36 | 11 | 16 | A |
| M32/M27 | 7071.032.027 | M32×1.5 | M27×1.5 | 36 | 11 | 16 | A |
| M40/M25 | 7071.040.025 | M40×1.5 | M25×1.5 | 45 | 13 | 19 | A |
| M40/M30 | 7071.040.030 | M40×1.5 | M30×1.5 | 45 | 13 | 19 | A |
| M40/M32 | 7071.040.032 | M40×1.5 | M32×1.5 | 45 | 13 | 19 | A |
| M50/M32 | 7071.050.032 | M50×1.5 | M32×1.5 | 55 | 14 | 22 | A |
| M50/M40 | 7071.050.040 | M50×1.5 | M40×1.5 | 55 | 14 | 22 | A |
| M63/M40 | 7071.063.040 | M63×1.5 | M40×1.5 | 68 | 15 | 24 | A |
| M63/M50 | 7071.063.050 | M63×1.5 | M50×1.5 | 68 | 15 | 24 | A |

MJH-PG 制螺纹 标准规格

| 螺纹规格 | 订货编号 | 外螺纹规格 | 内螺纹规格 | 扳手尺寸 (SW) | 螺纹长度 (L) | 总长度 (H) | 形式 |
|-------------|--------------|--------|--------|--------------|-------------|------------|----|
| PG9/PG7 | 7071.109.107 | PG9 | PG7 | 18 | 7 | 10 | A |
| PG11/PG9 | 7071.111.109 | PG11 | PG9 | 21 | 7 | 10.5 | A |
| PG13.5/PG11 | 7071.135.111 | PG13.5 | PG11 | 23 | 7 | 10.5 | A |
| PG16/PG13.5 | 7071.116.135 | PG16 | PG13.5 | 26 | 7 | 10.5 | A |
| PG21/PG16 | 7071.121.116 | PG21 | PG16 | 32 | 7 | 11 | A |
| PG29/PG21 | 7071.129.121 | PG29 | PG21 | 45 | 8 | 13 | A |
| PG36/PG29 | 7071.136.129 | PG36 | PG29 | 50 | 9 | 14 | A |
| PG48/PG42 | 7071.148.142 | PG48 | PG42 | 65 | 10 | 16 | A |

MZH-金属增扩环

- 产品材质：黄铜镀镍
- 橡胶件：三元乙丙橡胶；
- 温度：-40℃—+100℃；
- 防护等级：IP68

产品特性：螺纹增扩功能

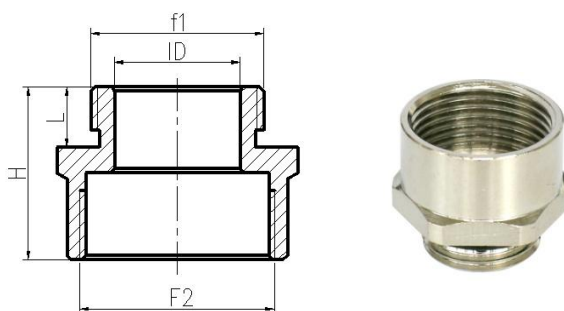

MZH-M 制螺纹 标准规格

| 螺纹规格 | 订货编号 | 外螺纹规格 | 内螺纹规格 | 扳手尺寸 (SW) | 螺纹长度 (L1) | 总长度 (L) | 内孔 |
|---------|--------------|---------|---------|--------------|--------------|------------|----|
| M12/M16 | 7081.012.016 | M12×1.5 | M16×1.5 | 19 | 6 | 16 | 8 |
| M16/M18 | 7081.016.018 | M16×1.5 | M18×1.5 | 22 | 7 | 17.5 | 12 |
| M16/M20 | 7081.016.020 | M16×1.5 | M20×1.5 | 23 | 7 | 18.5 | 12 |
| M18/M20 | 7081.018.020 | M18×1.5 | M20×1.5 | 23 | 7 | 18.5 | 14 |
| M20/M25 | 7081.020.025 | M20×1.5 | M25×1.5 | 28 | 7 | 18 | 16 |
| M25/M30 | 7081.025.030 | M25×1.5 | M30×1.5 | 34 | 7 | 19.5 | 21 |
| M25/M32 | 7081.025.032 | M25×1.5 | M32×1.5 | 36 | 7 | 20 | 21 |
| M30/M36 | 7081.030.036 | M30×1.5 | M36×1.5 | 40 | 8 | 23.5 | 25 |
| M32/M40 | 7081.032.040 | M32×1.5 | M40×1.5 | 45 | 8 | 23.5 | 27 |
| M36/M48 | 7081.036.048 | M36×1.5 | M48×1.5 | 52 | 8 | 27 | 31 |
| M40/M58 | 7081.040.050 | M40×1.5 | M50×1.5 | 55 | 9 | 28 | 35 |
| M50/M63 | 7081.050.063 | M50×1.5 | M63×1.5 | 70 | 10 | 30.5 | 44 |

MZH-NPT 制螺纹 标准规格

| 螺纹规格 | 订货编号 | 外螺纹规格 | 内螺纹规格 | 扳手尺寸 (SW) | 螺纹长度 (L1) | 总长度 (L) | 内孔 |
|-------------------------|----------------|------------|------------|--------------|--------------|------------|----|
| NPT 1/2" / NPT 3/4" | 7081.N12.N34 | NPT 1/2" | NPT 3/4" | 30 | 13 | 29 | 15 |
| NPT 3/4" / NPT 1" | 7081.N34.N1 | NPT 3/4" | NPT 1" | 38 | 13 | 34 | 20 |
| NPT 3/4" / NPT 1 1/4" | 7081.N34.N114 | NPT 3/4" | NPT 1 1/4" | 45 | 13 | 36.5 | 20 |
| NPT 3/4" / NPT 1 1/2" | 7081.N34.N112 | NPT 3/4" | NPT 1 1/2" | 52 | 13 | 36.5 | 20 |
| NPT 1" / NPT 1 1/4" | 7081.N1.N114 | NPT 1" | NPT 1 1/4" | 45 | 16 | 38.5 | 26 |
| NPT 1" / NPT 2" | 7081.N1.N2 | NPT 1" | NPT 2" | 65 | 16 | 38.5 | 26 |
| NPT 1 1/4" / NPT 1 1/2" | 7081.N114.N112 | NPT 1 1/4" | NPT 1 1/2" | 52 | 16 | 38.5 | 34 |
| NPT 1 1/4" / NPT 2" | 7081.N114.N2 | NPT 1 1/4" | NPT 2" | 65 | 18 | 41 | 40 |

MZH-金属增扩环

- 产品材质：黄铜镀镍
- 橡胶件：三元乙丙橡胶；
- 温度：-40℃—+100℃；
- 防护等级：IP68

产品特性：螺纹增扩功能

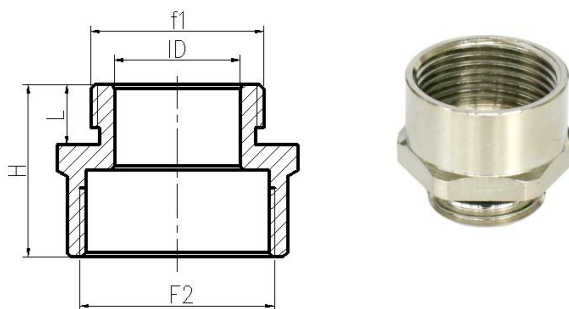

MZH-PG 制螺纹 标准规格

| 螺纹规格 | 订货编号 | 外螺纹规格 | 内螺纹规格 | 扳手尺寸 (SW) | 螺纹长度 (L1) | 总长度 (L) | 内孔 |
|-------------|--------------|--------|--------|--------------|--------------|------------|------|
| PG7/PG9 | 7081.P07.P09 | PG7 | PG9 | 18 | 6 | 16 | 9 |
| PG9/PG11 | 7081.P09.P11 | PG9 | PG11 | 22 | 7 | 18 | 11.5 |
| PG9/PG13.5 | 7081.P09.P13 | PG9 | PG13.5 | 24 | 7 | 18 | 11.5 |
| PG11/PG13.5 | 7081.P11.P13 | PG11 | PG13.5 | 24 | 7 | 18 | 15 |
| PG11/PG16 | 7081.P11.P16 | PG11 | PG16 | 26 | 7 | 20 | 15 |
| PG11/PG21 | 7081.P11.P21 | PG11 | PG21 | 32 | 7 | 22 | 15 |
| PG11/PG16 | 7081.P11.P16 | PG13.5 | PG16 | 26 | 7 | 20 | 17 |
| PG13.5/PG21 | 7081.P13.P21 | PG13.5 | PG21 | 32 | 7 | 22 | 17 |
| PG16/PG21 | 7081.P16.P21 | PG16 | PG21 | 32 | 7 | 22 | 19 |
| PG16/PG29 | 7081.P16.P29 | PG16 | PG29 | 40 | 7 | 23 | 19 |
| PG21/PG29 | 7081.P21.P29 | PG21 | PG29 | 40 | 7 | 23 | 23 |
| PG29/PG36 | 7081.P29.P36 | PG29 | PG36 | 50 | 8 | 27.5 | 32.5 |
| PG36/PG42 | 7081.P36.P42 | PG36 | PG42 | 58 | 9 | 31 | 42.5 |
| PG42/PG48 | 7081.P42.P48 | PG42 | PG48 | 65 | 10 | 33 | 48 |

MZH-G 管制螺纹 标准规格

| 螺纹规格 | 订货编号 | 外螺纹规格 | 内螺纹规格 | 扳手尺寸 (SW) | 螺纹长度 (L1) | 总长度 (L) | 内孔 |
|-------------------|----------------|----------|----------|--------------|--------------|------------|----|
| G1/4" / G3/8" | 7081.G14.G38 | G 1/4" | G 3/8" | 20 | 8 | 20.5 | 9 |
| G1/4" / G1/2" | 7081.G14.G12 | G 1/4" | G 1/2" | 24 | 8 | 20.5 | 9 |
| G3/8" / G1/2" | 7081.G38.G12 | G 3/8" | G 1/2" | 24 | 8 | 20.5 | 12 |
| G1/2" / G1" | 7081.G12.G1 | G 1/2" | G 1" | 36 | 8 | 23.5 | 16 |
| G1/2" / 1 1/4" | 7081.G12.G114 | G 1/2" | G 1 1/4" | 45 | 8 | 27 | 16 |
| G3/4" / G1" | 7081.G34.G1 | G 3/4" | G 1" | 45 | 8 | 26.5 | 21 |
| G1" / G1 1/4" | 7081.G1.G114 | G 1" | G 1 1/4" | 36 | 13 | 32 | 27 |
| G1 1/4" / G1 1/2" | 7081.G114.G112 | G 1 1/4" | G 1 1/2" | 52 | 13 | 31 | 34 |
| G2" / G2 1/2" | 7081.G2.G212 | G 2" | G 2 1/2" | 80 | 13 | 35 | 53 |

MNH-金属内螺纹环

- 产品材质：黄铜镀镍
- 橡胶件：三元乙丙橡胶；
- 温度：-40℃—+80℃；

产品特性：螺纹间连接作用

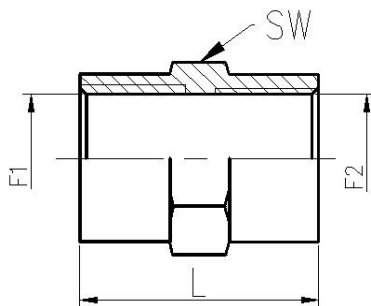

MNH-M 制螺纹 标准规格

| 螺纹规格 F1/F2 | 订货编号 | 总长 L | 扳手尺寸 SW | 包装 |
|------------------|--------------|------|------------|----|
| M10×1.5/ M10×1.5 | 7061.010.010 | 16 | 12 | 50 |
| M12×1.5/ M12×1.5 | 7061.012.012 | 16 | 14 | 50 |
| M16×1.5/ M16×1.5 | 7061.016.016 | 18 | 19 | 50 |
| M20×1.5/ M20×1.5 | 7061.020.020 | 22 | 23 | 50 |
| M24×1.5/ M24×1.5 | 7061.024.024 | 22 | 27 | 50 |
| M25×1.5/ M25×1.5 | 7061.025.025 | 22 | 28 | 25 |
| M27×1.5/ M27×1.5 | 7061.027.027 | 22 | 30 | 25 |
| M32×1.5/ M32×1.5 | 7061.032.032 | 24 | 36 | 10 |
| M40×1.5/ M40×1.5 | 7061.040.040 | 30 | 45 | 5 |
| M48×1.5/ M48×1.5 | 7061.048.048 | 35 | 52 | 5 |
| M50×1.5/ M50×1.5 | 7061.050.050 | 35 | 55 | 1 |
| M63×1.5/ M63×1.5 | 7061.063.063 | 42 | 70 | 1 |

NRP-PG 制螺纹 标准规格

| 螺纹规格 F1/F2 | 订货编号 | 总长 L | 扳手尺寸 SW | 包装 |
|-----------------|--------------|------|------------|----|
| PG7 / PG7 | 7061.107.107 | 15 | 14 | 50 |
| PG9 / PG9 | 7061.109.109 | 15 | 17 | 50 |
| PG11 / PG11 | 7061.111.111 | 18 | 20 | 50 |
| PG13.5 / PG13.5 | 7061.135.135 | 22 | 22 | 50 |
| PG16 / PG16 | 7061.116.116 | 22 | 24 | 50 |
| PG21 / PG21 | 7061.121.121 | 24 | 30 | 25 |
| PG29 / PG29 | 7061.129.129 | 30 | 40 | 25 |
| PG36 / PG36 | 7061.136.136 | 35 | 50 | 10 |
| PG48 / PG48 | 7061.148.148 | 42.5 | 65 | 10 |

NTEM-尼龙变径环

- 1、材质：采用 PA66 原料，防火等级 UL94-V2
- 2、用途：此产品可将不同的螺纹外径尺寸进行自由转换；可根据客户要求定制，生产不同螺纹长度及其他不同螺纹之间的转换

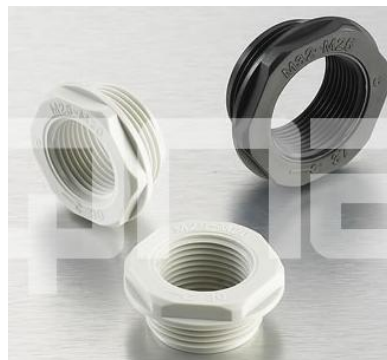
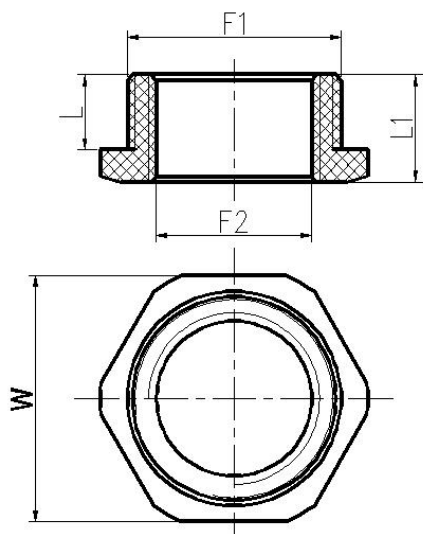

NTEM-

| 型号 | 外螺纹规格 | 内螺纹规格 | L 螺纹长度 | L1 螺纹长度 | W 宽度 | 包装 |
|---------|---------|---------|--------|---------|------|--------|
| M16-M12 | M16X1.5 | M12X1.5 | 8 | 12 | 22 | 100pcs |
| M20-M16 | M20X1.5 | M16X1.5 | 8 | 12 | 24.2 | 100pcs |
| M25-M20 | M25X1.5 | M20X1.5 | 10 | 15 | 29 | 100pcs |
| M32-M25 | M32X1.5 | M25X1.5 | 10 | 15 | 35.9 | 50pcs |
| M40-M32 | M40X1.5 | M32X1.5 | 10 | 15 | 45.8 | 25pcs |
| M50-M40 | M50X1.5 | M40X1.5 | 11.5 | 15 | 55 | 25pcs |
| M63-M50 | M63X1.5 | M50X1.5 | 11.5 | 16 | 67.5 | 25pcs |

快速软管接头

- 1、安装快速、敏捷、方便
- 2、不含卤素、磷，符合欧盟 RoHs，REACH 指令
- 3、防护等级到达 IP65

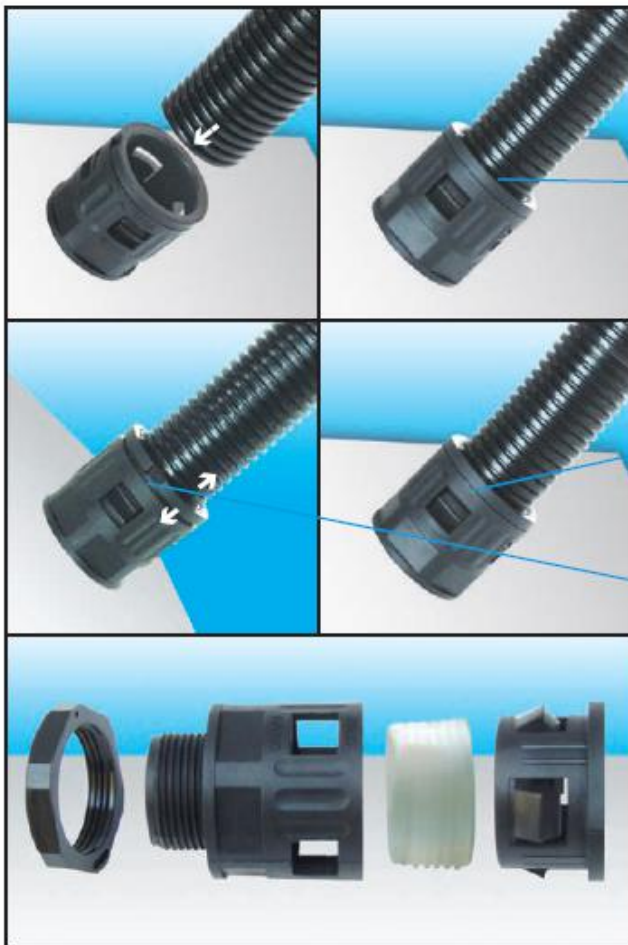

安装方便只需轻轻一插



卸装方便、更可靠

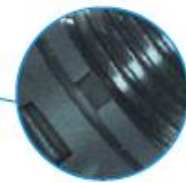

防护等级高达IP67

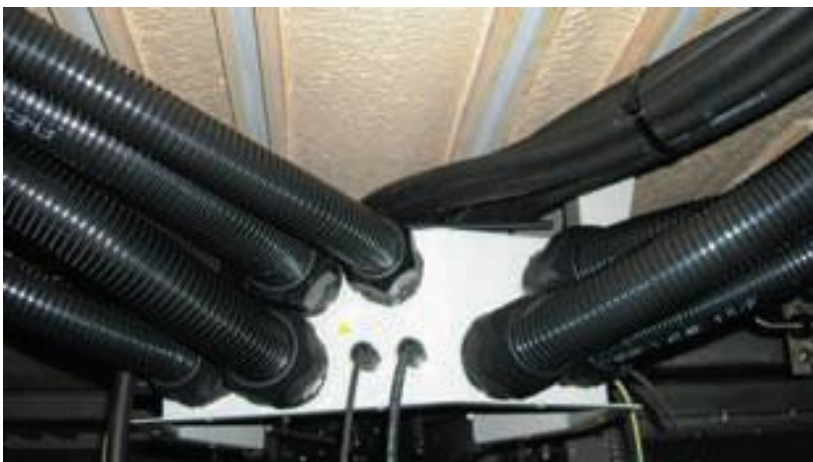

NTB 尼龙软管

- 产品材质：PA6,(防火等级 UL94-V2),
- 温度：-40℃—+100℃;
- 颜色种类：黑色、灰色,选购时请确定 B (黑色) ,G (灰色)
- 产品特性：
柔韧性好，回复性能强、表面光滑、抗扭曲、高的机械强度，能够耐酸碱、油污、耐弱酸、抗氧化、耐紫外线 (UV)。
- 应用场合： 轨道交通、地铁车辆、电力机车等；机械制造；电气绝缘保护；照明设备；航空设备；其他涉及电气安全的场合



NTB-

| 规格 | 订货编号 黑色 | 订货编号 灰色 | 内径×外径 mm | 静态半径 mm | 动态半径 mm | 包装 m | 重量 g/m |
|------------|------------|------------|-------------|------------|------------|---------|-----------|
| NTB-AD10.0 | NTB.A10.B | NTB.A10.G | 6.50×10.0 | 15 | 30 | 100 | 21 |
| NTB-AD13.0 | NTB.A13.B | NTB.A13.G | 10.0×13.0 | 20 | 40 | 100 | 27 |
| NTB-AD15.8 | NTB.A15.B | NTB.A15.G | 12.0×15.8 | 25 | 45 | 100 | 38 |
| NTB-AD18.5 | NTB.A18.B | NTB.A18.G | 14.3×18.5 | 35 | 50 | 50 | 46 |
| NTB-AD21.2 | NTB.A21.B | NTB.A21.G | 17.0×21.2 | 40 | 70 | 50 | 62 |
| NTB-AD28.5 | NTB.A28.B | NTB.A28.G | 23.0×28.5 | 45 | 100 | 50 | 98 |
| NTB-AD34.5 | NTB.A34.B | NTB.A34.G | 29.0×34.5 | 55 | 120 | 25 | 114 |
| NTB-AD42.5 | NTB.A42.B | NTB.A42.G | 36.0×42.5 | 65 | 150 | 25 | 168 |
| NTB-AD54.5 | NTB.A54.B | NTB.A54.G | 48.0×54.5 | 80 | 190 | 25 | 224 |

NTBV 尼龙软管 (V0 等级)

- 产品材质：PA6,(防火等级 UL94-V0),
- 温度：-40℃—+100℃;
- 颜色种类：黑色、灰色,选购时请确定 B (黑色 RAL 9005) ,G (灰色 RAL 7037)
- 产品特性：
柔韧性好，回复性能强、表面光滑、抗扭曲、高的机械强度，能够耐酸碱、油污、耐弱酸、抗氧化、耐紫外线 (UV)。
- 应用场合： 轨道交通、地铁车辆、电力机车等；机械制造；电气绝缘保护；照明设备；航空设备；其他涉及电气安全的场合



NTBV-

| 规格 | 订货编号 黑色 | 订货编号 灰色 | 内径×外径 mm | 静态半径 mm | 动态半径 mm | 包装 m | 重量 g/m |
|-------------|------------|------------|-------------|------------|------------|---------|-----------|
| NTBV-AD10.0 | NTBV.A10.B | NTBV.A10.G | 6.50×10.0 | 15 | 30 | 100 | 21 |
| NTBV-AD13.0 | NTBV.A13.B | NTBV.A13.G | 10.0×13.0 | 20 | 40 | 100 | 27 |
| NTBV-AD15.8 | NTBV.A15.B | NTBV.A15.G | 12.0×15.8 | 25 | 45 | 100 | 38 |
| NTBV-AD18.5 | NTBV.A18.B | NTBV.A18.G | 14.3×18.5 | 35 | 50 | 50 | 46 |
| NTBV-AD21.2 | NTBV.A21.B | NTBV.A21.G | 17.0×21.2 | 40 | 70 | 50 | 62 |
| NTBV-AD28.5 | NTBV.A28.B | NTBV.A28.G | 23.0×28.5 | 45 | 100 | 50 | 98 |
| NTBV-AD34.5 | NTBV.A34.B | NTBV.A34.G | 29.0×34.5 | 55 | 120 | 25 | 114 |
| NTBV-AD42.5 | NTBV.A42.B | NTBV.A42.G | 36.0×42.5 | 65 | 150 | 25 | 168 |
| NTBV-AD54.5 | NTBV.A54.B | NTBV.A54.G | 48.0×54.5 | 80 | 190 | 25 | 224 |

FTB 聚乙烯软管

- 产品材质：聚乙烯，
- 温度：-20℃—+80℃；
- 颜色种类：黑色、灰色,选购时请确定 B（黑色）,G（灰色）
- 产品特性：
柔韧性好，机械承载强度小、表面光滑、抗扭曲、高的机械强度，能够耐酸碱、油污、耐弱酸、抗氧化、耐紫外线（UV）。
- 应用场合： 轨道交通、地铁车辆、电力机车等；机械制造；电气绝缘保护；照明设备；航空设备；



FTB-

| 规格 | 订货编号 黑色 | 订货编号 灰色 | 内径×外径 mm | 静态半径 mm | 动态半径 mm | 包装 m | 重量 g/m |
|------------|------------|------------|-------------|------------|------------|---------|-----------|
| FTB-AD10.0 | FTB.A10.B | FTB.A10.G | 6.50×10.0 | 15 | 30 | 100 | 21 |
| FTB-AD13.0 | FTB.A13.B | FTB.A13.G | 10.0×13.0 | 20 | 40 | 100 | 27 |
| FTB-AD15.8 | FTB.A15.B | FTB.A15.G | 12.0×15.8 | 25 | 45 | 100 | 38 |
| FTB-AD18.5 | FTB.A18.B | FTB.A18.G | 14.3×18.5 | 35 | 50 | 50 | 46 |
| FTB-AD21.2 | FTB.A21.B | FTB.A21.G | 17.0×21.2 | 40 | 70 | 50 | 62 |
| FTB-AD28.5 | FTB.A28.B | FTB.A28.G | 23.0×28.5 | 45 | 100 | 50 | 98 |
| FTB-AD34.5 | FTB.A34.B | FTB.A34.G | 29.0×34.5 | 55 | 120 | 25 | 114 |
| FTB-AD42.5 | FTB.A42.B | FTB.A42.G | 36.0×42.5 | 65 | 150 | 25 | 168 |
| FTB-AD54.5 | FTB.A54.B | FTB.A54.G | 48.0×54.5 | 80 | 190 | 25 | 224 |

NWB PET 编织套管

- 产品材质：PET,符合 RoSH 要求,
- 温 度：-50℃— +150℃;
- 阻燃等级 V0
- 颜色种类：黑色、灰色,选购时请确定 B（黑色）,G（灰色）
- 产品特性：柔韧性好，PET 材料具有伸缩性，弹性及耐磨性，阻燃编织管。
- 应用场合： 轨道交通、地铁车辆、电力机车等；



NWB-

| 规格 | 内径 mm | 伸缩范围 mm | 包装 | 订货编号（黑色） | 订货编号（灰色） |
|----------|----------|------------|-----|------------|------------|
| NWB-3.2 | 3.2 | 2.3-6.3 | 200 | NWB-3.2.B | NWB-3.2.G |
| NWB-6.4 | 6.4 | 3.2-9.5 | 200 | NWB-6.4.B | NWB-6.4.G |
| NWB-8.0 | 8.0 | 6.0-11.0 | 200 | NWB-8.0.B | NWB-8.0.G |
| NWB-9.5 | 9.5 | 4.7-15.9 | 200 | NWB-9.5.B | NWB-9.5.G |
| NWB-12.7 | 12.7 | 6.4-19.0 | 100 | NWB-12.7.B | NWB-12.7.G |
| NWB-19.1 | 19.1 | 12-31.5 | 100 | NWB-19.1.B | NWB-19.1.G |
| NWB-23.0 | 23.0 | 15-34 | 100 | NWB-23.0.B | NWB-23.0.G |
| NWB-31.8 | 31.8 | 19-38.0 | 100 | NWB-31.8.B | NWB-31.8.G |
| NWB-38.1 | 38.1 | 25-57.1 | 100 | NWB-38.1.B | NWB-38.1.G |
| NWB-44.5 | 44.5 | 31.5-63.5 | 100 | NWB-44.5.B | NWB-44.5.G |
| NWB-50.8 | 50.8 | 31.7-69.8 | 50 | NWB-50.8.B | NWB-50.8.G |
| NWB-63.5 | 63.5 | 40.1-78.6 | 50 | NWB-63.5.B | NWB-63.5.G |

NFG 尼龙软管快速接头

- 产品材质：PA66(UL94 -V2);
- 橡胶件：三元乙丙胶;
- 温度：-20℃—+80℃;
- 防护等级：IP56，使用合适的密封圈;
- 颜色种类：黑色、灰色,选购时请确定 B（黑色）,G（灰色）;
- 产品特性：连接安装各种规格的软管;

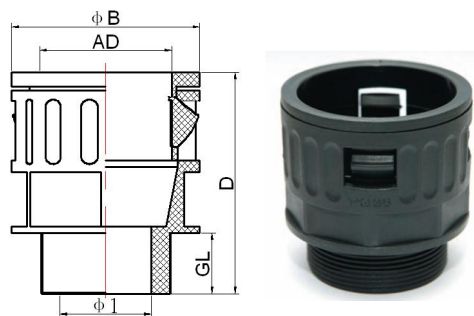

NFG-GM、M 制螺纹 标准规格

| 适配软管 | 编号及规格（黑色） | 螺牙规格 | 螺纹外径 | 螺纹长度 | 包装 |
|--------|---------------|-----------|------|------|----|
| AD10.0 | NFG-M12 -10.0 | M12 x 1.5 | 12 | 8.5 | 50 |
| AD13.0 | NFG-M16 -13.0 | M16 x 1.5 | 16 | 10 | 50 |
| AD15.8 | NFG-M18 -15.8 | M18 x 1.5 | 18 | 12.5 | 50 |
| AD15.8 | NFG-M20 -15.8 | M20 x 1.5 | 20 | 12.5 | 50 |
| AD18.5 | NFG-M20 -18.5 | M20 x 1.5 | 20 | 12.5 | 50 |
| AD18.5 | NFG-M22 -18.5 | M22 x 1.5 | 22 | 12.5 | 50 |
| AD21.2 | NFG-M20 -21.2 | M20 x 1.5 | 20 | 13 | 50 |
| AD21.2 | NFG-M22 -21.2 | M22 x 1.5 | 22 | 13 | 50 |
| AD21.2 | NFG-M24 -21.2 | M24 x 1.5 | 24 | 13 | 50 |
| AD21.2 | NFG-M25 -21.2 | M25 x 1.5 | 25 | 13 | 50 |
| AD28.5 | NFG-M25 -28.5 | M25 x 1.5 | 25 | 13 | 20 |
| AD28.5 | NFG-M27 -28.5 | M27 x 1.5 | 27 | 13 | 20 |
| AD28.5 | NFG-M30-28.5 | M30 x 2.0 | 30 | 13 | 20 |
| AD28.5 | NFG-M32 -28.5 | M32 x 1.5 | 32 | 13 | 20 |
| AD34.5 | NFG-M32 -34.5 | M32 x 1.5 | 32 | 14 | 10 |
| AD34.5 | NFG-M36 -34.5 | M36 x 2.0 | 36 | 14 | 10 |
| AD34.5 | NFG-M40 -34.5 | M40 x 1.5 | 40 | 14 | 10 |
| AD42.5 | NFG-M40 -42.5 | M40 x 1.5 | 40 | 15 | 8 |
| AD42.5 | NFG-M48 -42.5 | M48 x 2.0 | 48 | 15 | 8 |
| AD54.5 | NFG-M50 -54.5 | M50 x 1.5 | 50 | 16 | 5 |
| AD54.5 | NFG-M60 -54.5 | M60 x 1.5 | 60 | 16 | 5 |
| AD54.5 | NFG-M63 -54.5 | M63 x 1.5 | 60 | 16 | 5 |

NFG 尼龙软管快速接头

- 产品材质：PA66(UL94 -V2);
- 橡胶件：三元乙丙胶;
- 温度：-20℃—+80℃;
- 防护等级：IP56，使用合适的密封圈;
- 颜色种类：黑色、灰色,选购时请确定 B (黑色),G (灰色);
- 产品特性：连接安装各种规格的软管;

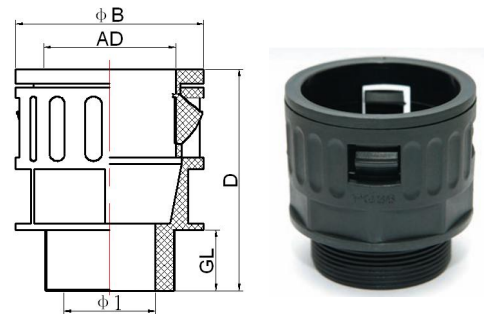

NFG-PG 德制螺纹

| 适配软管 | 编号及规格 (黑色) | 螺牙规格 | 螺纹外径 | 螺纹长度 | 包装 |
|--------|-----------------|--------|------|------|----|
| AD10.0 | NFG-PG7-10.0 | PG7 | 12.4 | 8.5 | 50 |
| AD13.0 | NFG-PG9-13.0 | PG9 | 15.2 | 10 | 50 |
| AD15.8 | NFG-PG11-15.8 | PG11 | 18.4 | 12.5 | 50 |
| AD18.5 | NFG-PG13.5-18.5 | PG13.5 | 20.4 | 12.5 | 50 |
| AD21.2 | NFG-PG16-21.2 | PG16 | 22.5 | 13 | 50 |
| AD28.5 | NFG-PG21-28.5 | PG21 | 28.3 | 13 | 20 |
| AD34.5 | NFG-PG29-34.5 | PG29 | 37 | 14 | 10 |
| AD42.5 | NFG-PG36-42.5 | PG36 | 47 | 15 | 8 |
| AD54.5 | NFG-PG42-54.5 | PG42 | 54 | 16 | 5 |
| AD54.5 | NFG-PG48-54.5 | PG48 | 59.3 | 16 | 5 |

NFG-G 管制螺纹

| 适配软管 | 编号及规格 (黑色) | 螺牙规格 | 螺纹外径 | 螺纹长度 | 包装 |
|--------|------------------|-------------|------|------|----|
| AD10.0 | NFG-G1/4 -10.0 | G(PF) 1/4 | 13.1 | 8.5 | 50 |
| AD13.0 | NFG-G3/8 -13.0 | G(PF) 3/8 | 16.6 | 10 | 50 |
| AD1.58 | NFG-G3/8 -1.58 | G(PF) 3/8 | 16.6 | 12.5 | 50 |
| AD1.58 | NFG-G1/2 -1.58 | G(PF) 1/2 | 20.9 | 12.5 | 50 |
| AD18.5 | NFG-G1/2 -18.5 | G(PF) 1/2 | 20.9 | 12.5 | 50 |
| AD21.2 | NFG-G1/2 -21.2 | G(PF) 1/2 | 20.9 | 13 | 50 |
| AD21.2 | NFG-G3/4 -21.2 | G(PF) 3/4 | 26.4 | 13 | 50 |
| AD25.0 | NFG-G3/4 -25 | G(PF) 3/4 | 26.4 | 13 | 50 |
| AD28.5 | NFG-G3/4 -28.5 | G(PF) 3/4 | 26.4 | 13 | 20 |
| AD34.5 | NFG-G1 -34.5 | G(PF) 1 | 33.2 | 14 | 10 |
| AD42.5 | NFG-G1 1/4 -42.5 | G(PF) 1 1/4 | 41.9 | 15 | 8 |
| AD54.5 | NFG-G1 1/2 -54.5 | G(PF) 1 1/2 | 48 | 16 | 5 |
| AD54.5 | NFG-G2 -54.5 | G(PF) 2 | 60 | 16 | 5 |

RNFG 90度尼龙软管快速接头

- 产品材质：PA66(UL94 -V2);
- 橡胶件：三元乙丙胶;
- 温度：-20℃—+80℃;
- 防护等级：IP56 用合适的密封圈;
- 颜色种类：黑色、灰色,选购时请确定 B (黑色) ,G (灰色);
- 产品特性：连接安装各种规格的软管;

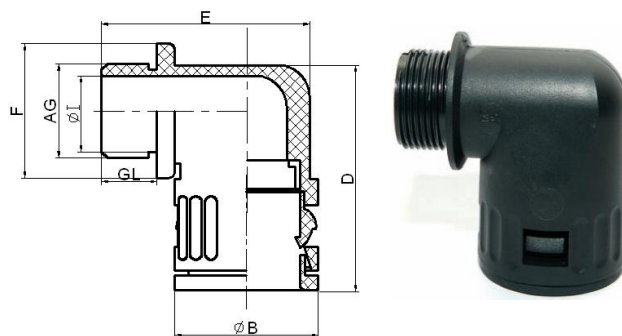

RNFG-GM、M 制螺纹 标准规格

| 适配软管 | 编号及规格 (黑色) | 螺牙规格 | 螺纹外径 | 螺纹长度 |
|--------|---------------|-----------|------|------|
| AD10.0 | RNFG-M12-10.0 | M12 x 1.5 | 12 | 10 |
| AD13.0 | RNFG-M16-13.0 | M16 x 1.5 | 16 | 10 |
| AD13.0 | RNFG-M18-13.0 | M18 x 1.5 | 18 | 10 |
| AD15.8 | RNFG-M18-15.8 | M18 x 1.5 | 18 | 12.5 |
| AD15.8 | RNFG-M20-15.8 | M20 x 1.5 | 20 | 12.5 |
| AD18.5 | RNFG-M18-18.5 | M18 x 1.5 | 18 | 13 |
| AD18.5 | RNFG-M20-18.5 | M20 x 1.5 | 20 | 13 |
| AD21.2 | RNFG-M20-21.2 | M20 x 1.5 | 20 | 13 |
| AD21.2 | RNFG-M24-21.2 | M24 x 1.5 | 24 | 13 |
| AD21.2 | RNFG-M25-21.2 | M25 x 1.5 | 25 | 13 |
| AD28.5 | RNFG-M25-28.5 | M25 x 1.5 | 25 | 13 |
| AD28.5 | RNFG-M27-28.5 | M27 x 1.5 | 27 | 13 |
| AD28.5 | RNFG-M30-28.5 | M30 x 1.5 | 30 | 13 |
| AD34.5 | RNFG-M32-34.5 | M32 x 1.5 | 32 | 14.5 |
| AD34.5 | RNFG-M36-34.5 | M36 x 1.5 | 36 | 14.5 |
| AD34.5 | RNFG-M40-34.5 | M40 x 1.5 | 40 | 14.5 |
| AD42.5 | RNFG-M40-42.5 | M40 x 1.5 | 40 | 15 |
| AD42.5 | RNFG-M50-42.5 | M50 x 1.5 | 50 | 15 |
| AD54.5 | RNFG-M50-54.5 | M50 x 1.5 | 50 | 16 |
| AD54.5 | RNFG-M63-54.5 | M63 x 1.5 | 63 | 16 |

RNFG 90度尼龙软管快速接头

- 产品材质：PA66(UL94 -V2);
- 橡胶件：三元乙丙胶;
- 温度：-20℃—+80℃;
- 防护等级：IP56 用合适的密封圈;
- 颜色种类：黑色、灰色,选购时请确定 B (黑色),G (灰色);
- 产品特性：连接安装各种规格的软管;

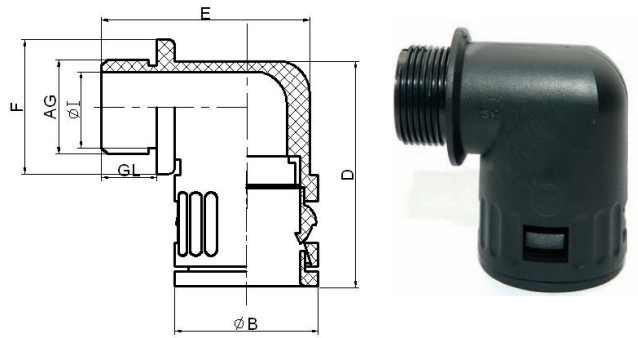

RNFG-PG 德制螺纹 标准规格

| 适配软管 | 编号及规格 (黑色) | 螺牙规格 | 螺纹外径 | 螺纹长度 |
|--------|------------------|--------|------|------|
| AD10.0 | RNFG-PG7-10.0 | PG7 | 12.5 | 10 |
| AD13.0 | RNFG-PG9-13.0 | PG9 | 15.2 | 10 |
| AD15.8 | RNFG-PG11-15.8 | PG11 | 18.6 | 12.5 |
| AD15.8 | RNFG-PG13.5-15.8 | PG13.5 | 20.4 | 12.5 |
| AD18.5 | RNFG-PG13.5-18.5 | PG13.5 | 20.4 | 13 |
| AD21.2 | RNFG-PG16-21.2 | PG16 | 22.5 | 13 |
| AD28.5 | RNFG-PG21-28.5 | PG21 | 28.3 | 13 |
| AD34.5 | RNFG-PG29-34.5 | PG29 | 37 | 14.5 |
| AD42.5 | RNFG-PG36-42.5 | PG36 | 47 | 15 |
| AD42.5 | RNFG-PG42-42.5 | PG42 | 54 | 15 |
| AD54.5 | RNFG-PG48-54.5 | PG48 | 59.3 | 16 |

RNFG-G 管制螺纹 标准规格

| 适配软管 | 编号及规格 (黑色) | 螺牙规格 | 螺纹外径 | 螺纹长度 |
|--------|------------------|------------|------|------|
| AD10.0 | RNFG-G1/4-10.0 | G(PF) 1/4 | 13.1 | 10 |
| AD13.0 | RNFG-G3/8-13.0 | G(PF) 3/8 | 16.6 | 10 |
| AD15.8 | RNFG-G3/8-15.8 | G(PF) 3/8 | 16.6 | 12.5 |
| AD21.2 | RNFG-G1/2-21.2 | G(PF) 1/2 | 20.9 | 13 |
| AD21.2 | RNFG-G1/2-21.2 | G(PF) 1/2 | 22.5 | 13 |
| AD25.0 | RNFG-G1/2-25.0 | G(PF) 1/2 | 25 | 13 |
| AD28.5 | RNFG-G3/4-28.5 | G(PF)3/4 | 28.3 | 13 |
| AD34.5 | RNFG-G1-34.5 | G(PF)1 | 37 | 14.5 |
| AD42.5 | RNFG-G1 1/4-42.5 | G(PF)1 1/4 | 41.9 | 15 |
| AD42.5 | RNFG-G1 1/2-42.5 | G(PF)1 1/2 | 48 | 15 |
| AD54.5 | RNFG-G1 1/2-54.5 | G(PF)1 1/2 | 48 | 16 |

RSFG 一体式带缩紧软管接头

- 产品材质：PA66(UL94 -V2);
- 橡胶件：三元乙丙胶;
- 温度：-20℃—+80℃;
- 防护等级：IP67，使用合适的密封圈;
- 颜色种类：黑色、灰色,选购时请确定 B (黑色),G (灰色);

产品特性：连接安装各种规格的软管

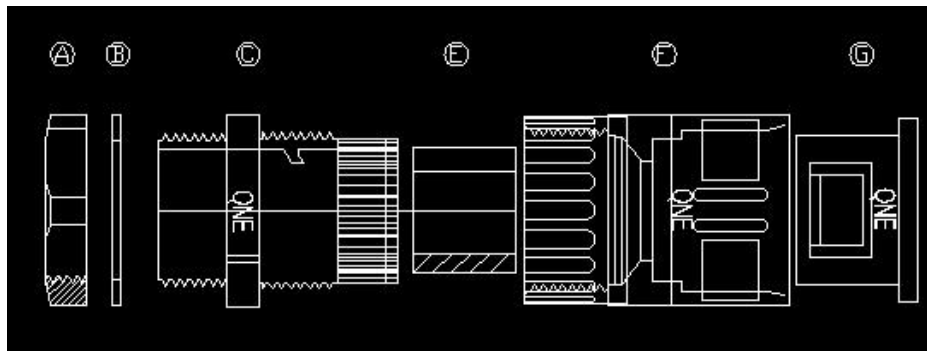

RSFG-M 公制螺纹

| 型号 (波纹管內螺纹加对应电缆接头型号号) | 波纹管 | 适配接头 (可选择对应电缆接头) |
|------------------------|--------|------------------|
| RSFG-M16(4-8)/AD13.0 | AD13.0 | NCG-M16(4-8) |
| RSFG-M16(5-10)/AD15.8 | AD15.8 | NCG-M16(5-10) |
| RSFG-M18(5-10)/AD15.8 | AD15.8 | NCG-M18(5-10) |
| RSFG-M20(6-12)/AD18.5 | AD18.5 | NCG-M20(6-12) |
| RSFG-M20(6-12)/AD21.2 | AD21.2 | NCG-M20(6-12) |
| RSFG-M22(10-14)/AD21.2 | AD21.2 | NCG-M22(10-14) |
| RSFG-M25(13-18)/AD28.5 | AD28.5 | NCG-M25(13-18) |
| RSFG-M32(18-25)/AD34.5 | AD34.5 | NCG-M32(18-25) |
| RSFG-M40(22-32)/AD42.5 | AD42.5 | NCG-M40(22-32) |

RMFG 防水软管接头

- 产品材质：PA66(UL94 -V2);
- 橡胶件：三元乙丙胶;
- 温度：-20℃—+80℃;
- 防护等级：IP67，使用合适的密封圈;
- 颜色种类：黑色、灰色,选购时请确定 B（黑色）,G（灰色）;

产品特性：连接安装各种规格的软管



RMFG -M 公制螺纹

| 适配软管 | 编号 | 螺牙规格 | 螺纹外径 | 螺纹长度 | 包装 |
|--------|---------------|-----------|------|------|----|
| AD13.0 | RMFG-M16-13.0 | M16 x 1.5 | 16 | 15 | 50 |
| AD15.8 | RMFG-M16-15.8 | M16 x 1.5 | 16 | 15 | 50 |
| AD15.8 | RMFG-M20-15.8 | M20 x 1.5 | 20 | 15 | 50 |
| AD15.8 | RMFG-M22-15.8 | M22 x 1.5 | 22 | 15 | 50 |
| AD15.8 | RMFG-M25-15.8 | M25 x 1.5 | 25 | 15 | 50 |
| AD18.5 | RMFG-M16-18.5 | M16 x 1.5 | 16 | 15 | 50 |
| AD18.5 | RMFG-M20-18.5 | M20 x 1.5 | 20 | 15 | 50 |
| AD18.5 | RMFG-M22-18.5 | M22 x 1.5 | 22 | 15 | 50 |
| AD21.2 | RMFG-M20-21.2 | M20 x 1.5 | 20 | 15 | 50 |
| AD21.2 | RMFG-M25-21.2 | M25 x 1.5 | 25 | 15 | 50 |
| AD25.0 | RMFG-M25-25.0 | M25 x 1.5 | 25 | 15 | 50 |
| AD28.5 | RMFG-M25-28.5 | M25 x 1.5 | 25 | 15 | 50 |
| AD34.5 | RMFG-M32-34.5 | M32 x 1.5 | 32 | 15 | 20 |
| AD42.5 | RMFG-M40-42.5 | M40 x 1.5 | 40 | 15 | 10 |
| AD42.5 | RMFG-M50-42.5 | M50 x 1.5 | 50 | 15 | 10 |
| AD54.5 | RMFG-M50-54.5 | M50 x 1.5 | 50 | 22 | 10 |
| AD54.5 | RMFG-M63-54.5 | M63 x 1.5 | 63 | 25 | 10 |

RMFG 防水软管接头

- 产品材质：PA66(UL94 -V2);
- 橡胶件：三元乙丙胶;
- 温度：-20℃—+80℃;
- 防护等级：IP67，使用合适的密封圈;
- 颜色种类：黑色、灰色,选购时请确定 B（黑色）,G（灰色）;

产品特性：连接安装各种规格的软管



RMFG -PG 德制螺纹

| 适配软管 | 编号 | 螺牙规格 | 螺纹外径 | 螺纹长度 | 包装 |
|--------|------------------|--------|------|------|----|
| AD10.0 | RMFG-PG7-10.0 | PG7 | 12.5 | 9 | 50 |
| AD10.0 | RMFG-PG9-10.0 | PG9 | 15.2 | 9 | 50 |
| AD13.0 | RMFG-PG11-13.0 | PG11 | 18.6 | 10 | 50 |
| AD15.8 | RMFG-PG13.5-15.8 | PG13.5 | 20.4 | 10 | 50 |
| AD15.8 | RMFG-PG16-15.8 | PG16 | 22.5 | 10.8 | 50 |
| AD18.5 | RMFG-PG13.5-18.5 | PG13.5 | 20.4 | 10 | 50 |
| AD18.5 | RMFG-PG16-18.5 | PG16 | 22.5 | 10.8 | 50 |
| AD21.2 | RMFG-PG16-21.2 | PG16 | 22.5 | 13 | 50 |
| AD21.2 | RMFG-PG21-21.2 | PG21 | 28.3 | 13 | 50 |
| AD28.5 | RMFG-PG21-28.5 | PG21 | 28.3 | 13 | 50 |
| AD34.5 | RMFG-PG29-34.5 | PG29 | 37 | 13 | 20 |
| AD42.5 | RMFG-PG36-42.5 | PG36 | 47 | 13 | 10 |
| AD54.5 | RMFG-PG48-54.5 | PG48 | 59.3 | 16 | 10 |

RMFG -G 管制螺纹

| 适配软管 | 编号 | 螺牙规 | 螺纹外径 | 螺纹长度 | 包装 |
|--------|-------------------|------------|------|------|----|
| AD13.0 | RMFG-PF3/8-13.0 | G(PF)3/8 | 16.6 | 15 | 50 |
| AD15.8 | RMFG-PF1/2-15.8 | G(PF)1/2 | 20.9 | 15 | 50 |
| AD18.5 | RMFG-PF1/2-18.5 | G(PF)1/2 | 20.9 | 15 | 50 |
| AD21.2 | RMFG-PF1/2-21.2 | G(PF)1/2 | 20.9 | 15 | 50 |
| AD21.2 | RMFG-PF3/4-21.2 | G(PF)3/4 | 26.4 | 15 | 50 |
| AD28.5 | RMFG-PF3/4-28.5 | G(PF)3/4 | 26.4 | 15 | 50 |
| AD34.5 | RMFG-PF1-34.5 | G(PF)1 | 33.2 | 15 | 20 |
| AD42.5 | RMFG-PF1 1/4-42.5 | G(PF)1 1/4 | 41.9 | 15 | 10 |
| AD54.5 | RMFG-PF1 1/2-54.5 | G(PF)1 1/2 | 48 | 15 | 10 |

YNFG Y型尼龙快速接头

- 产品材质：PA6
- 橡胶件：三元乙丙胶；
- 温度：-20℃—+80℃；
- 防护等级：IP67，使用合适的密封圈；
- 颜色种类：黑色、灰色,选购时请确定 B（黑色）,G（灰色）；
- 产品特性：连接安装各种规格的软管



YNFG-制螺纹 标准规格

| 规格 | 适配软管 | | | 订货编号 黑色 |
|------------------|--------|--------|--------|-----------------|
| | 1 | 2 | 3 | |
| AD10.0/2xAD10 | AD10.0 | AD10.0 | AD10.0 | 3520.10.10.10.B |
| AD21.2/2xAD15.8 | AD21.2 | AD15.8 | AD15.8 | 3520.21.15.15.B |
| AD28.5/2xAD15.8 | AD28.5 | AD15.8 | AD15.8 | 3520.28.15.15.B |
| AD18.5/2xAD18.5 | AD18.5 | AD18.5 | AD18.5 | 3520.18.18.18.B |
| AD21.2/2xAD21.2 | AD21.2 | AD21.2 | AD21.2 | 3520.21.21.21.B |
| AD28.5/2xAD21.2 | AD28.5 | AD21.2 | AD21.2 | 3520.28.21.21.B |
| *AD34.5/2xAD28.5 | AD34.5 | AD28.5 | AD28.5 | 3520.34.28.28.B |
| *AD42.5/2xAD34.5 | AD42.5 | AD34.5 | AD34.5 | 3520.42.34.34.B |
| *AD54.5/2xAD42.5 | AD54.5 | AD42.5 | AD42.5 | 3520.54.42.42.B |

* 需确定交货日期

INFG 内螺纹尼龙软管快速接头

- 产品材质：PA6
- 橡胶件：三元乙丙胶；
- 温度：-20℃—+80℃；
- 防护等级：IP67，使用合适的密封圈；
- 颜色种类：黑色、灰色,选购时请确定 B（黑色）,G（灰色）；
- 产品特性：连接安装各种规格的软管；

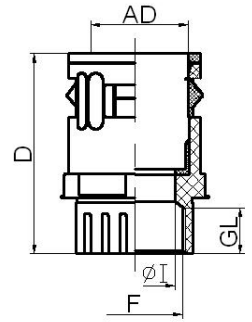

INFG-GM、M 制螺纹 标准规格

| 螺纹规格 | 适配软管 | 订货编号 黑色 |
|--------------|--------|----------------|
| INFG-M16X1.5 | AD15.8 | 3620.016.A15.B |
| INFG-M20X1.5 | AD21.2 | 3620.020.A21.B |
| INFG-M25X1.5 | AD28.5 | 3620.025.A28.B |
| INFG-M32X1.5 | AD34.5 | 3620.032.A34.B |

SKM 金属紧固夹

- 1、金属材料：镀锌铁
- 2、橡胶件：丁腈橡胶、硅橡胶



| 规格/编号 | 螺丝孔 | 厚度 | 宽度 |
|------------|-----|-----|----|
| SKM-AD10.0 | M4 | 0.5 | 16 |
| SKM-AD13.0 | M6 | 0.5 | 16 |
| SKM-AD15.8 | M6 | 0.5 | 16 |
| SKM-AD18.5 | M6 | 0.5 | 16 |
| SKM-AD21.0 | M6 | 0.5 | 16 |
| SKM-AD28.5 | M6 | 0.5 | 16 |
| SKM-AD34.5 | M6 | 0.6 | 16 |
| SKM-AD42.5 | M6 | 0.6 | 16 |
| SKM-AD54.5 | M6 | 0.6 | 16 |

CNS-带盖软管支架

- 产品材质：PA6
- 温 度：-20℃—+80℃；
- 防护等级：IP67，使用合适的密封圈；
- 颜色种类：黑色、灰色,选购时请确定 G（黑色）,G（灰色）；
- 产品特性：连接安装各种规格的软管，将其固定；

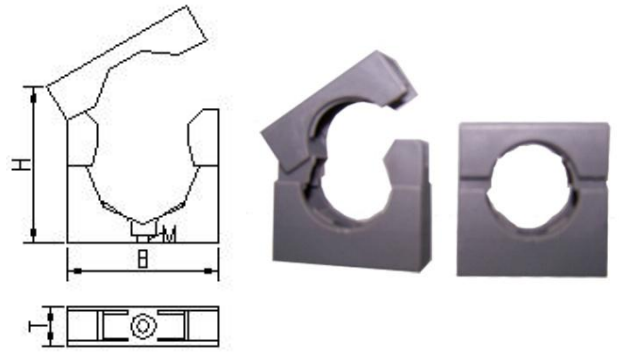

CNS- 标准规格

| 螺纹规格 | 适配软管 | 订货编号 黑色 | 订货编号 灰色 | 孔径 M | 高度 H | 宽度 B | T |
|---------------|--------|--------------|--------------|---------|---------|---------|------|
| CNS-AD10/M4 | AD10.0 | CNS.A10.M4.B | CNS.A10.M4.G | 4 | 23 | 30 | 12.5 |
| CNS-AD13.0/M4 | AD13.0 | CNS.A13.M4.B | CNS.A13.M4.G | 4 | 27 | 30 | 11 |
| CNS-AD15.8/M4 | AD15.8 | CNS.A15.M4.B | CNS.A15.M4.G | 4 | 28 | 30 | 12.5 |
| CNS-AD18.5/M5 | AD18.5 | CNS.A18.M5.B | CNS.A18.M5.G | 5 | 30 | 32 | 13.5 |
| CNS-AD21.2/M5 | AD21.2 | CNS.A21.M5.B | CNS.A21.M5.G | 5 | 34 | 35 | 14.5 |
| CNS-AD28.5/M6 | AD28.5 | CNS.A28.M6.B | CNS.A28.M6.G | 6 | 42 | 42 | 15.5 |
| CNS-AD34.5/M6 | AD34.5 | CNS.A34.M6.B | CNS.A34.M6.G | 6 | 48 | 51 | 16 |
| CNS-AD42.5/M6 | AD42.5 | CNS.A42.M6.B | CNS.A42.M6.G | 6 | 56 | 61 | 19 |
| CNS-AD54.5/M6 | AD54.5 | CNS.A54.M6.B | CNS.A54.M6.G | 6 | 69 | 74 | 18.5 |

CNSH-不带盖软管支架

- 产品材质：PA6
- 温度：-20℃—+80℃；
- 防护等级：IP67，使用合适的密封圈；
- 颜色种类：黑色、灰色,选购时请确定 G（黑色）,G（灰色）；
- 产品特性：连接安装各种规格的软管，将其固定

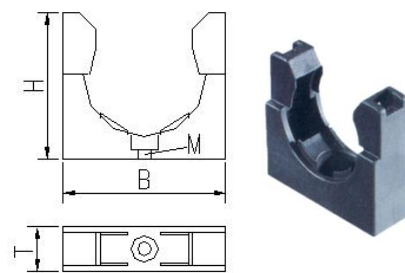

CNSH- 标准规格

| 螺纹规格 | 适配软管 | 订货编号 黑色 | 订货编号 灰色 | 孔径 M | 高度 H | 宽度 B | T |
|----------------|--------|---------------|---------------|---------|---------|---------|------|
| CNSH-AD10/M4 | AD10.0 | CNSH.A10.M4.B | CNSH.A10.M4.G | 4 | 23 | 30 | 12.5 |
| CNSH-AD13.0/M4 | AD13.0 | CNSH.A13.M4.B | CNSH.A13.M4.G | 4 | 23 | 30 | 11 |
| CNSH-AD15.8/M4 | AD15.8 | CNSH.A15.M4.B | CNSH.A15.M4.G | 4 | 23 | 30 | 12.5 |
| CNSH-AD18.5/M5 | AD18.5 | CNSH.A18.M5.B | CNSH.A18.M5.G | 5 | 30 | 32 | 13.5 |
| CNSH-AD21.2/M5 | AD21.2 | CNSH.A21.M5.B | CNSH.A21.M5.G | 5 | 30 | 35 | 14.5 |
| CNSH-AD28.5/M6 | AD28.5 | CNSH.A28.M6.B | CNSH.A28.M6.G | 6 | 38 | 42 | 15.5 |
| CNSH-AD34.5/M6 | AD34.5 | CNSH.A34.M6.B | CNSH.A34.M6.G | 6 | 43 | 51 | 16 |
| CNSH-AD42.5/M6 | AD42.5 | CNSH.A42.M6.B | CNSH.A42.M6.G | 6 | 51 | 61 | 19 |
| CNSH-AD54.5/M6 | AD54.5 | CNSH.A54.M6.B | CNSH.A54.M6.G | 6 | 64 | 74 | 18.5 |

TTT-T 型三通

材 料 TPE
 温 度 -40℃- +100℃
 颜 色 灰色, 黑色
 供货周期 订货前请确认交货期

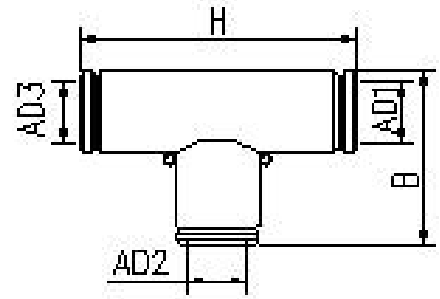

| 规格 | 孔径 | 长度 H | 宽度 B | 包装 | 订货编号 | |
|-----------------|----|------|------|----|---------------|---------------|
| | | | | | 黑色 | 灰色 |
| TTT-3×13.0 | 4 | 51 | 36 | 10 | T.13.13.13.B | T.13.13.13.G |
| TTT-3×15.8 | 4 | 63 | 44 | 10 | T.15.15.15.B | T.15.15.15.G |
| TTT-3×18.5 | 4 | 70.5 | 48.5 | 10 | T.18.18.18.B | T.18.18.18.G |
| TTT-3×21.2 | 4 | 71 | 50 | 10 | T.21.21.21.B | T.21.21.21.G |
| TTT-3×28.5 | 4 | 77 | 57.5 | 10 | T..28.28.28.B | T..28.28.28.G |
| TTT-3×34.5 | 4 | 85 | 64 | 10 | T..34.34.34.B | T..34.34.34.G |
| TTT-3×42.5 | 4 | 96 | 74.5 | 10 | T.42.42.42.B | T.42.42.42.G |
| TTT-2×15.8/21.2 | 4 | 65 | 50 | 10 | T.15.15.21.B | T.15.15.21.G |
| TTT-2×21.2/28.5 | 4 | 77 | 52 | 10 | T.21.21.28.B | T.21.21.28.G |
| TTT-2×28.5/34.5 | 4 | 83 | 57 | 10 | T.28.28.34.B | T.28.28.34.G |
| TTT-2×34.5/42.5 | 4 | 88 | 70 | 5 | T.34.34.42.B | T.34.34.42.G |

FNT- 软管闷头

材 料 TPE

温 度 -40℃- +100℃, 短时 130℃

颜 色 灰色 黑色

供货周期 备有大量现货, 特大量需确认

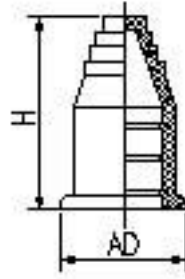

| 规格 | 对应软管 | 线径范围 | 高度 H | 包装 | 订货编号 黑色 |
|-------------|--------|-----------|---------|----|------------|
| FNT- AD10.0 | AD10.0 | 1.0-6.5 | 29.0 | 50 | FNT.10.B |
| FNT- AD13.0 | AD13.0 | 1.0-10.0 | 32.5 | 50 | FNT.13.B |
| FNT- AD15.8 | AD15.8 | 4.0-12.0 | 36.5 | 50 | FNT.15.B |
| FNT- AD18.5 | AD18.5 | 4.0-13.0 | 37.5 | 50 | FNT.18.B |
| FNT- AD21.2 | AD21.2 | 6.0-16.5 | 37.5 | 50 | FNT.21.B |
| FNT- AD28.5 | AD28.5 | 6.0-23.0 | 40.2 | 20 | FNT.28.B |
| FNT- AD34.5 | AD34.5 | 6.0-29.0 | 44.2 | 20 | FNT.34.B |
| FNT- AD42.5 | AD42.5 | 10.0-36.0 | 46.0 | 10 | FNT.42.B |
| FNT- AD54.5 | AD54.5 | 10.0-47.0 | 52.0 | 5 | FNT.54.B |

MPP-金属包塑管

- 产品结构：镀锌钢带，表面 PVC 熟料组成；
- 温 度：-20℃—+80℃；
- 颜色种类：黑色、灰色,选购时请确定 G（黑色）,G（灰色）；
- 产品特性：电气设备的连接，机车项目、空调等

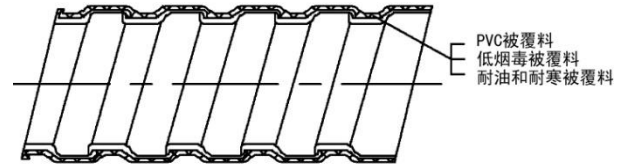

MPP-

| 公称内径 | 英制 | 内径 | 外径 | Kg/M | 订货编号 黑色 | 订货编号 灰色 |
|----------|--------|------|------|------------|------------|------------|
| MPP-Φ6 | 3/16" | 6.0 | 9.3 | 9.5kg/100m | MPP.006.B | MPP.006.G |
| MPP-Φ8 | 1/4" | 8.1 | 12.0 | 12kg/100m | MPP.008.B | MPP.008.G |
| MPP-Φ10 | 5/16" | 10.0 | 14.1 | 7.0kg/50m | MPP.010.B | MPP.010.G |
| MPP-Φ12 | 3/8" | 12.3 | 16.7 | 10.2kg/50m | MPP.012.B | MPP.012.G |
| MPP-Φ16 | 1/2" | 16.0 | 20.7 | 12.5kg/50m | MPP.016.B | MPP.016.G |
| MPP-Φ20 | 3/4" | 20.0 | 25.9 | 17.5kg/50m | MPP.020.B | MPP.020.G |
| MPP-Φ25 | 1" | 25.8 | 31.3 | 20.5kg/50m | MPP.025.B | MPP.025.G |
| MPP-Φ32 | 1-1/4" | 32.8 | 39.6 | 16kg/25m | MPP.032.B | MPP.032.G |
| MPP-Φ38 | 1-1/2" | 38.8 | 46.8 | 19.0kg/25m | MPP.038.B | MPP.038.G |
| MPP-Φ51 | 2" | 50.5 | 60.7 | 22.8kg/20m | MPP.051.B | MPP.051.G |
| MPP-Φ64 | 2-1/2" | 63.2 | 73.6 | 18.2kg/10m | MPP.064.B | MPP.064.G |
| MPP-Φ75 | 3" | 73.7 | 87.2 | 21.3kg/10m | MPP.075.B | MPP.075.G |
| MPP-Φ100 | 4" | 98.5 | 108 | 30kg/10m | MPP.100.B | MPP.100.G |

MPF-金属平包塑管

- 产品结构：镀锌钢带，表面 PVC 熟料组成；
- 温 度：-20℃—+80℃；
- 颜色种类：黑色、灰色,选购时请确定 G（黑色）,G（灰色）；
- 产品特性：电气设备的连接，机车项目、空调等



MPF-

| 公称内径 | 英制 | 内径 | 外径 | 弯曲半径 | 订货编号 黑色 | 色订货编号 灰色 |
|---------|--------|------|-------|------|------------|-------------|
| MPF-Φ12 | 3/8" | 12.3 | 17.8 | 60 | MPF.006.B | MPF.006.G |
| MPFΦ16 | 1/2" | 16.0 | 21.2 | 80 | MPF.008.B | MPF.008.G |
| MPFΦ20 | 3/4" | 20.0 | 26.4 | 100 | MPF.010.B | MPF.010.G |
| MPFΦ25 | 1" | 25.8 | 33.2 | 150 | MPF.012.B | MPF.012.G |
| MPFΦ32 | 1-1/4" | 32.8 | 42.0 | 180 | MPF.016.B | MPF.016.G |
| MPFΦ38 | 1-1/2" | 38.8 | 47.3 | 220 | MPF.020.B | MPF.020.G |
| MPFΦ51 | 2" | 50.5 | 61.4 | 250 | MPF.025.B | MPF.025.G |
| MPFΦ64 | 2-1/2" | 63.3 | 74.2 | 300 | MPF.032.B | MPF.032.G |
| MPFΦ75 | 3" | 77.7 | 88.6 | 450 | MPF.038.B | MPF.038.G |
| MPFΦ100 | 4" | 98.5 | 110.1 | 600 | MPF.051.B | MPF.051.G |

SPP-不锈钢编织软管

- 产品结构：外层不锈钢丝，中间 PVC，内部金属；
- 温 度： -20℃—+80℃；
- 产品特性：耐高温铁屑，有很好的防烫伤功能；耐切屑液，冷却液等腐蚀；
- 应用场合 适合于持续或经常性出现高温铁屑的场合，如车床加工区域，钻床加工区域等；

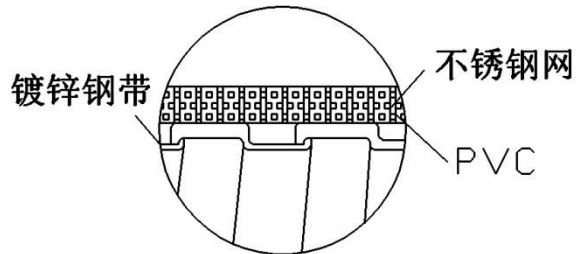

SPP-

| 公称内径 mm | 英制 | 最小内径 mm | 外径 mm | 弯曲半径 mm | 每卷长度 m | 订货编号 |
|------------|-------|------------|----------|------------|-----------|-------------|
| SPP-Φ10 | 1/4 | 9.7 | 14.7 | 40 | 50 | SPP.010.001 |
| SPP-Φ12 | 3/8 | 11.65 | 16.7 | 50 | 50 | SPP.012.001 |
| SPP-Φ16 | 1/2 | 14.65 | 20.0 | 70 | 25 | SPP.016.001 |
| SPP-Φ20 | 3/4 | 19.60 | 25.5 | 80 | 25 | SPP.020.001 |
| SPP-Φ25 | 1 | 24.50 | 31.5 | 110 | 20 | SPP.025.001 |
| SPP-Φ32 | 1-1/4 | 31.50 | 39.2 | 130 | 20 | SPP.032.001 |
| SPP-Φ38 | 1-1/2 | 37.40 | 46.2 | 180 | 10 | SPP.038.001 |
| SPP-Φ51 | 2 | 50.00 | 61.3 | 200 | 10 | SPP.051.001 |
| SPP-Φ64 | 2-1/2 | 62.50 | 74.1 | 260 | 10 | SPP.064.001 |
| SPP-Φ75 | 3 | 75.00 | 88.00 | 320 | 10 | SPP.075.001 |

MET-金属端式接头

- 材 料：外部金属为黄铜镀镍
- 密封件材料为丁腈橡胶
- 防护等级 使用合适的 O 形密封圈，防护等级可以达到 IP65
- 应用场合 高温，环境恶劣的场合
可提供不锈钢材质

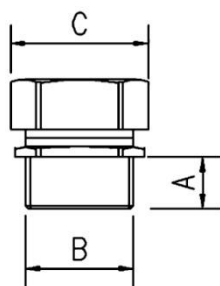

MET M 国标公制外螺纹

螺纹标准：GB/T192-2003 GB/T196-2003

| 螺纹规格 | 适配软管 | 产品编号 | A | B | C | 包装 |
|--------------|------|--------------|----|-------|-------|----|
| MET-M12×1.5 | Φ6 | 4521.012.006 | 8 | 11.5 | 17.5 | 50 |
| MET-M16×1.5 | Φ8 | 4521.016.008 | 8 | 15.5 | 22.5 | 50 |
| MET-M16×1.5 | Φ10 | 4521.016.010 | 10 | 15.5 | 22.5 | 50 |
| MET-M20×1.5 | Φ10 | 4521.020.010 | 10 | 19.5 | 22.5 | 50 |
| MET-M18×1.5 | Φ12 | 4521.018.012 | 12 | 17.5 | 26.0 | 50 |
| MET-M20×1.5 | Φ12 | 4521.020.012 | 12 | 19.5 | 26.0 | 50 |
| MET-M20×1.5 | Φ16 | 4521.020.016 | 12 | 19.5 | 30.0 | 50 |
| MET-M24×1.5 | Φ16 | 4521.024.016 | 12 | 23.5 | 30.0 | 50 |
| MET-M25×1.5 | Φ16 | 4521.025.016 | 12 | 24.5 | 30.0 | 50 |
| MET-M25×1.5 | Φ20 | 4521.025.020 | 13 | 24.5 | 35.5 | 50 |
| MET-M27×2.0 | Φ20 | 4521.027.020 | 13 | 26.5 | 35.5 | 25 |
| MET-M30×2.0 | Φ20 | 4521.030.020 | 13 | 29.5 | 35.5 | 25 |
| MET-M32×1.5 | Φ20 | 4521.032.020 | 13 | 31.5 | 35.5 | 25 |
| MET-M32×1.5 | Φ25 | 4521.032.025 | 14 | 31.5 | 42.5 | 25 |
| MET-M33×2.0 | Φ25 | 4521.033.025 | 14 | 32.5 | 42.5 | 25 |
| MET-M36×2.0 | Φ25 | 4521.036.025 | 14 | 35.5 | 42.5 | 25 |
| MET-M40×1.5 | Φ32 | 4521.040.032 | 17 | 39.5 | 53.0 | 10 |
| MET-M42×2.0 | Φ32 | 4521.042.032 | 17 | 41.5 | 53.0 | 10 |
| MET-M48×2.0 | Φ38 | 4521.048.038 | 18 | 47.5 | 59.0 | 10 |
| MET-M50×1.5 | Φ38 | 4521.050.038 | 18 | 49.5 | 59.0 | 10 |
| MET-M60×2.0 | Φ51 | 4521.060.051 | 21 | 59.3 | 73.5 | 5 |
| MET-M63×1.5 | Φ51 | 4521.063.051 | 21 | 62.3 | 73.5 | 5 |
| MET-M64×2.0 | Φ51 | 4521.064.051 | 21 | 63.3 | 73.5 | 5 |
| MET-M72×2.0 | Φ64 | 4521.072.064 | 25 | 71.4 | 90.0 | 1 |
| MET-M75×2.0 | Φ64 | 4521.075.064 | 25 | 74.4 | 90.0 | 1 |
| MET-M76×2.0 | Φ64 | 4521.076.064 | 25 | 75.4 | 90.0 | 1 |
| MET-M88×2.0 | Φ75 | 4521.088.075 | 25 | 87.4 | 103.0 | 1 |
| MET-M114×2.0 | Φ100 | 4521.114.100 | 30 | 113.4 | 133.5 | 1 |

MET-金属端式接头

- 材 料：外部金属为黄铜镀镍
- 密封件材料为丁腈橡胶
- 防护等级 使用合适的 O 形密封圈，防护等级可以达到 IP65
- 应用场合 高温，环境恶劣的场合
可提供不锈钢材质

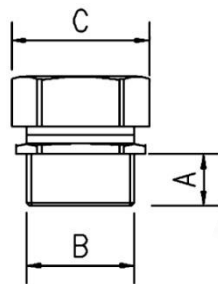

黄铜镀镍

MET G 牙外螺纹

螺纹标准：GB/T192-2003 GB/T196-2003

| 螺纹规格 | 适配软管 | 产品编号 | A | B | C | 包装 |
|-------------|------|---------------|----|-------|-------|----|
| MET-G1/4" | Φ6 | 4521.G14.006 | 8 | 11.5 | 17.5 | 50 |
| MET-G3/8" | Φ8 | 4521.G38.008 | 8 | 15.5 | 22.5 | 50 |
| MET-G3/8" | Φ10 | 4521.G38.010 | 10 | 15.5 | 22.5 | 50 |
| MET-G1/2" | Φ12 | 4521.G12.012 | 12 | 19.5 | 26.0 | 50 |
| MET-G1/2" | Φ16 | 4521.G12.016 | 12 | 19.5 | 30.0 | 50 |
| MET-G3/4" | Φ20 | 4521.G34.025 | 13 | 24.5 | 35.5 | 25 |
| MET-G1" | Φ25 | 4521.G1.025 | 14 | 31.5 | 42.5 | 10 |
| MET-G1-1/4" | Φ32 | 4521.G114.032 | 17 | 41.5 | 53.0 | 5 |
| MET-G1-1/2" | Φ38 | 4521.G112.038 | 18 | 49.5 | 59.0 | 5 |
| MET-G2" | Φ51 | 4521.G2.051 | 21 | 59.3 | 73.5 | 1 |
| MET-G2-1/2" | Φ64 | 4521.G212.064 | 25 | 71.4 | 90.0 | 1 |
| MET-G3" | Φ75 | 4521.G3.075 | 25 | 87.4 | 103.0 | 1 |
| MET-G4" | Φ100 | 4521.G4.100 | 30 | 113.4 | 133.5 | 1 |

KET-锌合金端式接头

- 材 料： 锌合金
- 密封件材料为丁腈橡胶
- 防护等级 使用合适的 O 形密封圈，防护等级可以达到 IP65
- 应用场合 高温，环境恶劣的场合
可提供不锈钢材质

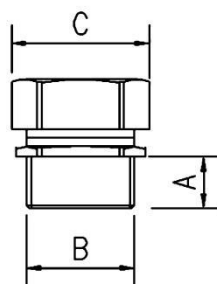

锌合金

KET M 国标公制外螺纹

螺纹标准：GB/T192-2003 GB/T196-2003

| 螺纹规格 | 适配软管 | 产品编号 | A | B | C | 包装 |
|--------------|------|--------------|----|-------|-------|----|
| KET-M12×1.5 | Φ6 | 4620.012.006 | 8 | 11.5 | 17.5 | 50 |
| KET-M16×1.5 | Φ8 | 4620.016.008 | 8 | 15.5 | 22.5 | 50 |
| KET-M16×1.5 | Φ10 | 4620.016.010 | 10 | 15.5 | 22.5 | 50 |
| KET-M20×1.5 | Φ10 | 4620.020.010 | 10 | 19.5 | 22.5 | 50 |
| KET-M18×1.5 | Φ12 | 4620.018.012 | 12 | 17.5 | 26.0 | 50 |
| KET-M20×1.5 | Φ12 | 4620.020.012 | 12 | 19.5 | 26.0 | 50 |
| KET-M20×1.5 | Φ16 | 4620.020.016 | 12 | 19.5 | 30.0 | 50 |
| KET-M24×1.5 | Φ16 | 4620.024.016 | 12 | 23.5 | 30.0 | 50 |
| KET-M25×1.5 | Φ16 | 4620.025.016 | 12 | 24.5 | 30.0 | 50 |
| KET-M25×1.5 | Φ20 | 4620.025.020 | 13 | 24.5 | 35.5 | 50 |
| KET-M27×2.0 | Φ20 | 4620.027.020 | 13 | 26.5 | 35.5 | 25 |
| KET-M30×2.0 | Φ20 | 4620.030.020 | 13 | 29.5 | 35.5 | 25 |
| KET-M32×1.5 | Φ20 | 4620.032.020 | 13 | 31.5 | 35.5 | 25 |
| KET-M32×1.5 | Φ25 | 4620.032.025 | 14 | 31.5 | 42.5 | 25 |
| KET-M33×2.0 | Φ25 | 4620.033.025 | 14 | 32.5 | 42.5 | 25 |
| KET-M36×2.0 | Φ25 | 4620.036.025 | 14 | 35.5 | 42.5 | 25 |
| KET-M40×1.5 | Φ32 | 4620.040.032 | 17 | 39.5 | 53.0 | 10 |
| KET-M42×2.0 | Φ32 | 4620.042.032 | 17 | 41.5 | 53.0 | 10 |
| KET-M48×2.0 | Φ38 | 4620.048.038 | 18 | 47.5 | 59.0 | 10 |
| KET-M50×1.5 | Φ38 | 4620.050.038 | 18 | 49.5 | 59.0 | 10 |
| KET-M60×2.0 | Φ51 | 4620.060.051 | 21 | 59.3 | 73.5 | 5 |
| KET-M63×1.5 | Φ51 | 4620.063.051 | 21 | 62.3 | 73.5 | 5 |
| KET-M64×2.0 | Φ51 | 4620.064.051 | 21 | 63.3 | 73.5 | 5 |
| KET-M72×2.0 | Φ64 | 4620.072.064 | 25 | 71.4 | 90.0 | 1 |
| KET-M75×2.0 | Φ64 | 4620.075.064 | 25 | 74.4 | 90.0 | 1 |
| KET-M76×2.0 | Φ64 | 4620.076.064 | 25 | 75.4 | 90.0 | 1 |
| KET-M88×2.0 | Φ75 | 4620.088.075 | 25 | 87.4 | 103.0 | 1 |
| KET-M114×2.0 | Φ100 | 4620.114.100 | 30 | 113.4 | 133.5 | 1 |

KET-锌合金端式接头

- 材 料：外部锌合金
- 密封件材料为丁腈橡胶
- 防护等级 使用合适的 O 形密封圈，防护等级可以达到 IP65
- 应用场合 高温，环境恶劣的场合
可提供不锈钢材质

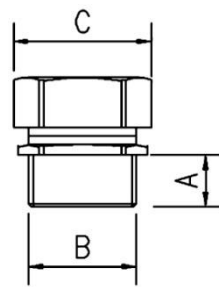

锌合金

KET G 牙外螺纹

螺纹标准：GB/T192-2003 GB/T196-2003

| 螺纹规格 | 适配软管 | 产品编号 | A | B | C | 包装 |
|-------------|------|---------------|----|-------|-------|----|
| KET-G1/4" | Φ6 | 4620.G14.006 | 8 | 11.5 | 17.5 | 50 |
| KET-G3/8" | Φ8 | 4620.G38.008 | 8 | 15.5 | 22.5 | 50 |
| KET-G3/8" | Φ10 | 4620.G38.010 | 10 | 15.5 | 22.5 | 50 |
| KET-G1/2" | Φ12 | 4620.G12.012 | 12 | 19.5 | 26.0 | 50 |
| KET-G1/2" | Φ16 | 4620.G12.016 | 12 | 19.5 | 30.0 | 50 |
| KET-G3/4" | Φ20 | 4620.G34.025 | 13 | 24.5 | 35.5 | 25 |
| KET-G1" | Φ25 | 4620.G1.025 | 14 | 31.5 | 42.5 | 10 |
| KET-G1-1/4" | Φ32 | 4620.G114.032 | 17 | 41.5 | 53.0 | 5 |
| KET-G1-1/2" | Φ38 | 4620.G112.038 | 18 | 49.5 | 59.0 | 5 |
| KET-G2" | Φ51 | 4620.G2.051 | 21 | 59.3 | 73.5 | 1 |
| KET-G2-1/2" | Φ64 | 4620.G212.064 | 25 | 71.4 | 90.0 | 1 |
| KET-G3" | Φ75 | 4620.G3.075 | 25 | 87.4 | 103.0 | 1 |
| KET-G4" | Φ100 | 4620.G4.100 | 30 | 113.4 | 133.5 | 1 |

SET-不锈钢端式接头

- 材 料：外部金属为不锈钢
- 密封件材料为丁腈橡胶
- 防护等级 使用合适的 O 形密封圈，防护等级可以达到 IP65
- 应用场合 高温，环境恶劣的场合

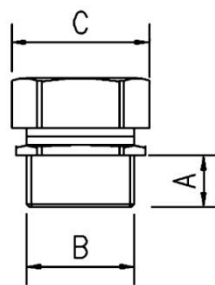

不锈钢

SET M 国标公制外螺纹

螺纹标准：GB/T192-2003 GB/T196-2003

| 螺纹规格 | 适配软管 | 产品编号 | A | B | C | 包装 |
|--------------|------|--------------|----|-------|-------|----|
| SET-M12×1.5 | Φ6 | 4721.012.006 | 8 | 11.5 | 17.5 | 50 |
| SET-M16×1.5 | Φ8 | 4721.016.008 | 8 | 15.5 | 22.5 | 50 |
| SET-M16×1.5 | Φ10 | 4721.016.010 | 10 | 15.5 | 22.5 | 50 |
| SET-M20×1.5 | Φ10 | 4721.020.010 | 10 | 19.5 | 22.5 | 50 |
| SET-M18×1.5 | Φ12 | 4721.018.012 | 12 | 17.5 | 26.0 | 50 |
| SET-M20×1.5 | Φ12 | 4721.020.012 | 12 | 19.5 | 26.0 | 50 |
| SET-M20×1.5 | Φ16 | 4721.020.016 | 12 | 19.5 | 30.0 | 50 |
| SET-M24×1.5 | Φ16 | 4721.024.016 | 12 | 23.5 | 30.0 | 50 |
| SET-M25×1.5 | Φ16 | 4721.025.016 | 12 | 24.5 | 30.0 | 50 |
| SET-M25×1.5 | Φ20 | 4721.025.020 | 13 | 24.5 | 35.5 | 50 |
| SET-M27×2.0 | Φ20 | 4721.027.020 | 13 | 26.5 | 35.5 | 25 |
| SET-M30×2.0 | Φ20 | 4721.030.020 | 13 | 29.5 | 35.5 | 25 |
| SET-M32×1.5 | Φ20 | 4721.032.020 | 13 | 31.5 | 35.5 | 25 |
| SET-M32×1.5 | Φ25 | 4721.032.025 | 14 | 31.5 | 42.5 | 25 |
| SET-M33×2.0 | Φ25 | 4721.033.025 | 14 | 32.5 | 42.5 | 25 |
| SET-M36×2.0 | Φ25 | 4721.036.025 | 14 | 35.5 | 42.5 | 25 |
| SET-M40×1.5 | Φ32 | 4721.040.032 | 17 | 39.5 | 53.0 | 10 |
| SET-M42×2.0 | Φ32 | 4721.042.032 | 17 | 41.5 | 53.0 | 10 |
| SET-M48×2.0 | Φ38 | 4721.048.038 | 18 | 47.5 | 59.0 | 10 |
| SET-M50×1.5 | Φ38 | 4721.050.038 | 18 | 49.5 | 59.0 | 10 |
| SET-M60×2.0 | Φ51 | 4721.060.051 | 21 | 59.3 | 73.5 | 5 |
| SET-M63×1.5 | Φ51 | 4721.063.051 | 21 | 62.3 | 73.5 | 5 |
| SET-M64×2.0 | Φ51 | 4721.064.051 | 21 | 63.3 | 73.5 | 5 |
| SET-M72×2.0 | Φ64 | 4721.072.064 | 25 | 71.4 | 90.0 | 1 |
| SET-M75×2.0 | Φ64 | 4721.075.064 | 25 | 74.4 | 90.0 | 1 |
| SET-M76×2.0 | Φ64 | 4721.076.064 | 25 | 75.4 | 90.0 | 1 |
| SET-M88×2.0 | Φ75 | 4721.088.075 | 25 | 87.4 | 103.0 | 1 |
| SET-M114×2.0 | Φ100 | 4721.114.100 | 30 | 113.4 | 133.5 | 1 |

SET-不锈钢端式接头

- 材 料：外部金属为不锈钢
- 密封件材料为丁腈橡胶
- 防护等级 使用合适的 O 形密封圈，防护等级可以达到 IP65
- 应用场合 高温，环境恶劣的场合

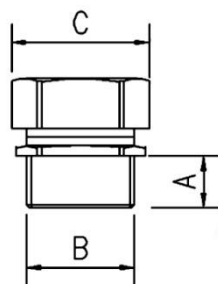

不锈钢

SET G 牙外螺纹

螺纹标准: GB/T192-2003 GB/T196-2003

| 螺纹规格 | 适配软管 | 产品编号 | A | B | C | 包装 |
|-------------|------|---------------|----|-------|-------|----|
| SET-G1/4" | Φ6 | 4721.G14.006 | 8 | 11.5 | 17.5 | 50 |
| SET-G3/8" | Φ8 | 4721.G38.008 | 8 | 15.5 | 22.5 | 50 |
| SET-G3/8" | Φ10 | 4721.G38.010 | 10 | 15.5 | 22.5 | 50 |
| SET-G1/2" | Φ12 | 4721.G12.012 | 12 | 19.5 | 26.0 | 50 |
| SET-G1/2" | Φ16 | 4721.G12.016 | 12 | 19.5 | 30.0 | 50 |
| SET-G3/4" | Φ20 | 4721.G34.025 | 13 | 24.5 | 35.5 | 25 |
| SET-G1" | Φ25 | 4721.G1.025 | 14 | 31.5 | 42.5 | 10 |
| SET-G1-1/4" | Φ32 | 4721.G114.032 | 17 | 41.5 | 53.0 | 5 |
| SET-G1-1/2" | Φ38 | 4721.G112.038 | 18 | 49.5 | 59.0 | 5 |
| SET-G2" | Φ51 | 4721.G2.051 | 21 | 59.3 | 73.5 | 1 |
| SET-G2-1/2" | Φ64 | 4721.G212.064 | 25 | 71.4 | 90.0 | 1 |
| SET-G3" | Φ75 | 4721.G3.075 | 25 | 87.4 | 103.0 | 1 |
| SET-G4" | Φ100 | 4721.G4.100 | 30 | 113.4 | 133.5 | 1 |

MGET-带缩紧金属端式接头

- 材 料：外部金属为黄铜镀镍
- 密封材料：改性橡胶
- 防护等级 使用合适的 O 形密封圈，防护等级可以达到 IP68
- 应用场合 高温，环境恶劣的场合

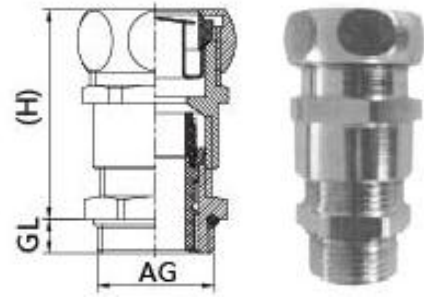

MGET M 国标公制外螺纹

螺纹标准：GB/T192-2003 GB/T196-2003

| 螺纹规格 | 适配软管 | 产品编号 | 卡扣范围 | 螺纹长度 GL | 扳手尺寸 | 包装 |
|-------------|------|-------------|-------|------------|------|----|
| M16X1.5/Φ8 | Φ8 | 4921.016.08 | 4-8 | 6 | 22 | 50 |
| M18X1.5/Φ10 | Φ10 | 4921.018.10 | 5-10 | 6 | 24 | 50 |
| M20X1.5/Φ12 | Φ12 | 4921.020.12 | 6-12 | 7 | 26 | 50 |
| M22X1.5/Φ16 | Φ16 | 4921.022.16 | 8-14 | 7 | 30 | 50 |
| M24X1.5/Φ16 | Φ16 | 4921.024.16 | 8-14 | 7 | 30 | 50 |
| M25X1.5/Φ16 | Φ16 | 4921.025.16 | 10-16 | 7 | 30 | 25 |
| M27X2.0/Φ20 | Φ20 | 4921.027.20 | 13-18 | 8 | 36 | 25 |
| M30X2.0/Φ20 | Φ20 | 4921.030.20 | 13-18 | 8 | 36 | 25 |
| M32X1.5/Φ20 | Φ20 | 4921.032.20 | 15-22 | 8 | 36 | 25 |
| M36X2.0/Φ25 | Φ25 | 4921.036.25 | 18-25 | 8 | 43 | 20 |
| M40X1.5/Φ32 | Φ32 | 4921.040.32 | 21-30 | 9 | 52 | 10 |
| M48X2.0/Φ32 | Φ32 | 4921.048.32 | 22-32 | 9 | 55 | 10 |
| M50X1.5/Φ38 | Φ38 | 4921.050.38 | 30-38 | 9 | 60 | 10 |
| M56X2.0/Φ38 | Φ38 | 4921.056.38 | 30-38 | 9 | 60 | 10 |

可订购铸铝、塑料、不锈钢机箱，机柜和各类机箱机柜集成



订货需知:



用户需知:

- ◇ 用户应提供产品及零配件，辅件的型号、规格、数量、交货期
- ◇ 特殊规格的产品应详细说明并提供与防水接头配合的螺纹规格及线缆系统布置图
- ◇ 若特殊定制，需注明产品材料型号及管件标志
- ◇ 如你的防水接头使用在特殊场所，请详细说明
- ◇ 如用户在设计、选型、使用产品是有困难，我公司派人到现场协助，

专业生产电缆紧固和保护产品，提供 24 小时技术支持，为你提供电缆紧固和保护的全套系统解决方案

